



Linear Motor Actuator

GLM20AP



For details, visit THK at www.thk.com

*Product information is updated regularly on the THK website.

THK CO., LTD.
TOKYO, JAPAN

CATALOG No.363-3E

Linear Motor Series

GLM

Flat Type with Core

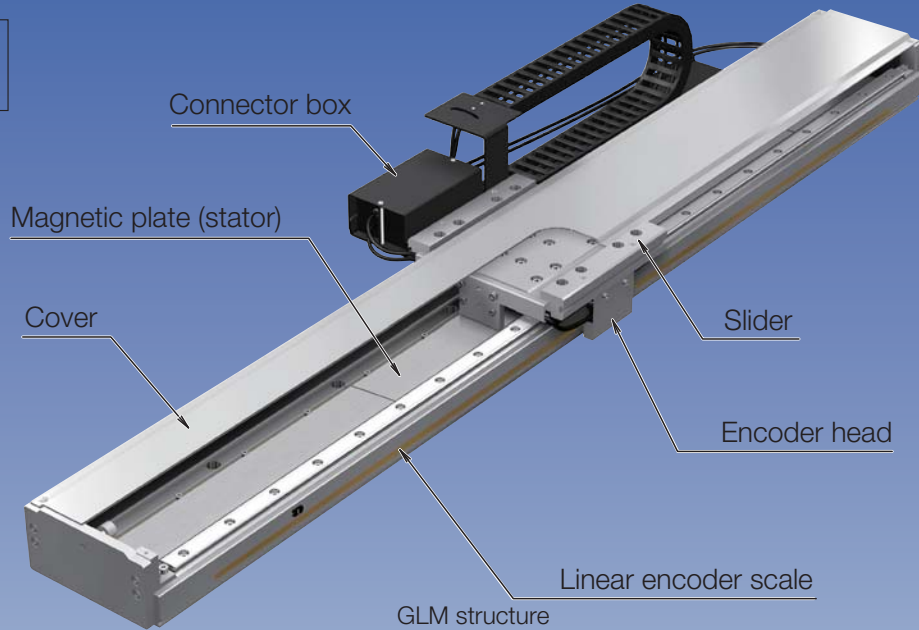

* The connector box is supported only on GLM20AP.

GLM is equipped with an AC linear servo motor with a core. An exceedingly strong magnetic field generated by a coil of wire surrounding an iron core provides the motor with characteristics such as high thrust and high acceleration/deceleration despite its small volume.

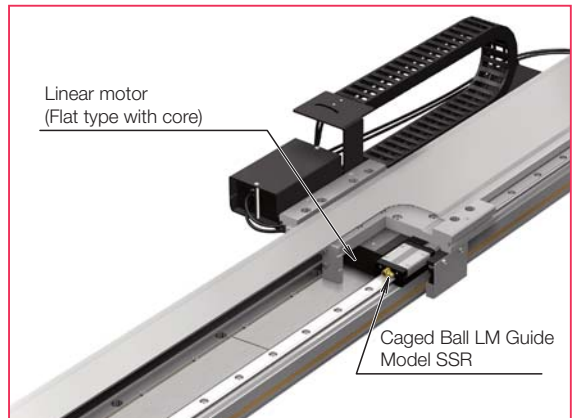

Structure diagram of Caged Ball LM Guide Model SSR

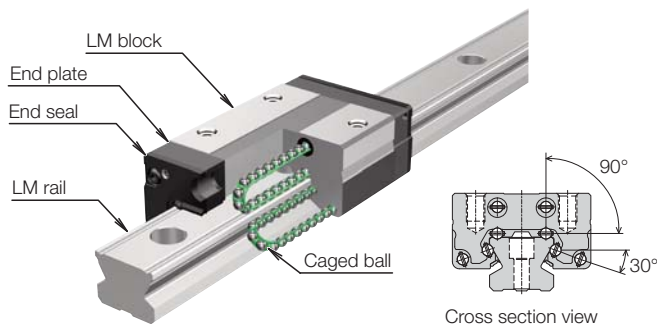

Caged Ball LM Guide Model SSR, equipped with caged balls that eliminate mutual friction between balls, has achieved low noise, good sound quality, long-term maintenance-free operation, long life, and high speed.

Features

1 High speed

The linear motor actuator, being capable of converting electromagnetic forces directly to linear motions, achieves high speeds even with long strokes.

GLM10 realizes the series' maximum speed of 4 m/s.
Other models can realize the maximum speed of 3 m/s.

2 High acceleration/deceleration and trackability

The use of aluminum parts in the slider has achieved weight reduction and realized high acceleration and deceleration of 2G.

Furthermore, the light weight and high rigidity of the slider have realized high trackability.

3 High accuracy

The full-closed control of the linear encoder* realizes a high positioning accuracy.

* Full-closed control: A method to directly detect the position of the moving slider using the linear encoder.

4 Long stroke

The linear motor actuator, to which magnetic plates can be added, supports long strokes that cannot be realized by a ball screw drive.

Furthermore, GLM20AP can support even longer strokes when joint base configuration is used.

5 Multi-slider support

More than one slider can be placed on the base of one axis, and each of them can be controlled independently.

6 Conformance to overseas standard

If a GLM model with a cable chain is selected, the acquisition of CE marking is supported.

Furthermore, GLM20AP is equipped with a newly designed motor to reduce temperature rises and support the UL standards.

The linear motor actuator realizes high speeds, high acceleration and deceleration, high accuracy, and conforms to safe and reliable overseas standard.



GLM20AP



Model configuration

Model number	Number of sliders/motor type	Stroke	Encoder/resolution	Magnetic pole sensor	Driver
GLM20AP	S	0490	R01K	J	TDP20

① **GLM20AP**

② **S:** S type
M: M type
L: L type
2S: S type x 2 (Multi-slider)
2M: M type x 2 (Multi-slider)
2L: L type x 2 (Multi-slider)

③ **0130:** 130 mm
to
2650: 2650 mm

④ **R01K:** 1.0 μm
R500: 0.5 μm
R100: 0.1 μm
H01K: 1.0 μm
G10K: 10.0 μm
G05K: 5.0 μm

⑤ **J:** With magnetic pole sensor
N: Without magnetic pole sensor

⑥ **TDP20:** Driver TDP 200 VAC specifications
TDP10: Driver TDP 100 VAC specifications

② Number of sliders + Motor type
Example: **2S**
2: Slider x 2
S: S type
Note) If there is one slider, there is no symbol for the number of sliders. If there are two sliders or more, contact THK.

③ See Table 1, "List of strokes."
* For details, see the GLM20AP dimension diagram (-> P.11 to 16).

④ See Table 2, "List of encoders."
Note) The maximum speed and repetitious positioning accuracy of the actuator vary depending on the encoder resolution.

⑤ The specification without a magnetic pole sensor detects the magnetic pole by servo ON input. While detecting the magnetic pole, the rod fluctuates a few millimeters from side to side for about 10 seconds. The magnetic pole detection may fail if an excessive load is applied to the slider, the work loaded on the slider has a barycentric position that is overhung, or an external force or high resistance acts on the slider. In this case, the specification with a magnetic pole sensor is recommended.

Table 1. List of strokes

Stroke [mm]	S type	0130	0310	0490	0670	0850	1030	1210	1390	1570	1750	1930	2110	2290	2470	2650
	M type	-	0160	0340	0520	0700	0880	1060	1240	1420	1600	1780	1960	2140	2320	2500
	L type	-	-	0200	0380	0560	0740	0920	1100	1280	1460	1640	1820	2000	2180	2360
Base length [mm]		400	580	760	940	1120	1300	1480	1660	1840	2020	2200	2380	2560	2740	2920
Total actuator length [mm]		420	600	780	960	1140	1320	1500	1680	1860	2040	2220	2400	2580	2760	2940

Note 1) The stroke is different if a multi-slider is used. For details, contact THK.

Note 2) The standard base length is recommended because the design complies with the magnet length.

Note 3) Maximum length of the single base is 4400mm. For joint base configuration, select an encoder made by Magnescale Co., Ltd. or HEIDENHAIN Inc. .

Table 2. List of encoders

Encoder manufacturer	Model number	Resolution [μm]	Repetitious positioning accuracy [μm]	Maximum speed [m/s]
Magnescale Co., Ltd.	PL25	G10K	10.0	3.0
Magnescale Co., Ltd.	PL25	G05K	5.0	
RENISHAW Inc.	RGH22X	R01K	1.0	1.5
HEIDENHAIN Inc.	LIDA277	H01K	1.0	
RENISHAW Inc.	RGH22Z	R500	0.5	
RENISHAW Inc.	RGH22Y	R100	0.1	

Note 1) The linear motor has different maximum speed and repetitious positioning accuracy depending on the encoder resolution.

Note 2) The maximum speed may be limited depending on the encoder to be used. For details, see the GLM20AP basic specifications (-> P.7).

Note 3) The resolution is the value after multiplying by 4.

Table 3. Drivers

⑥ Driver	Motor type	Attached driver
TDP20	SType	TDP-045CU-200AC-GA20SU-① ¹ -② ²
	MType	TDP-075CU-200AC-GA20MU-① ¹ -② ²
	LType	TDP-100CU-200AC-GA20LU-① ¹ -② ²
TDP10	SType	TDP-045CU-100AC-GA20SU-① ¹ -② ²
	MType	TDP-075CU-100AC-GA20MU-① ¹ -② ²

*1 The symbol ① setting of the attached driver complies with the actuator resolution. For details, see the driver model number (-> P.5).

*2 The symbol ② setting of the attached driver complies with the magnetic pole sensor of the actuator. For details, see the driver model number (-> P.5).

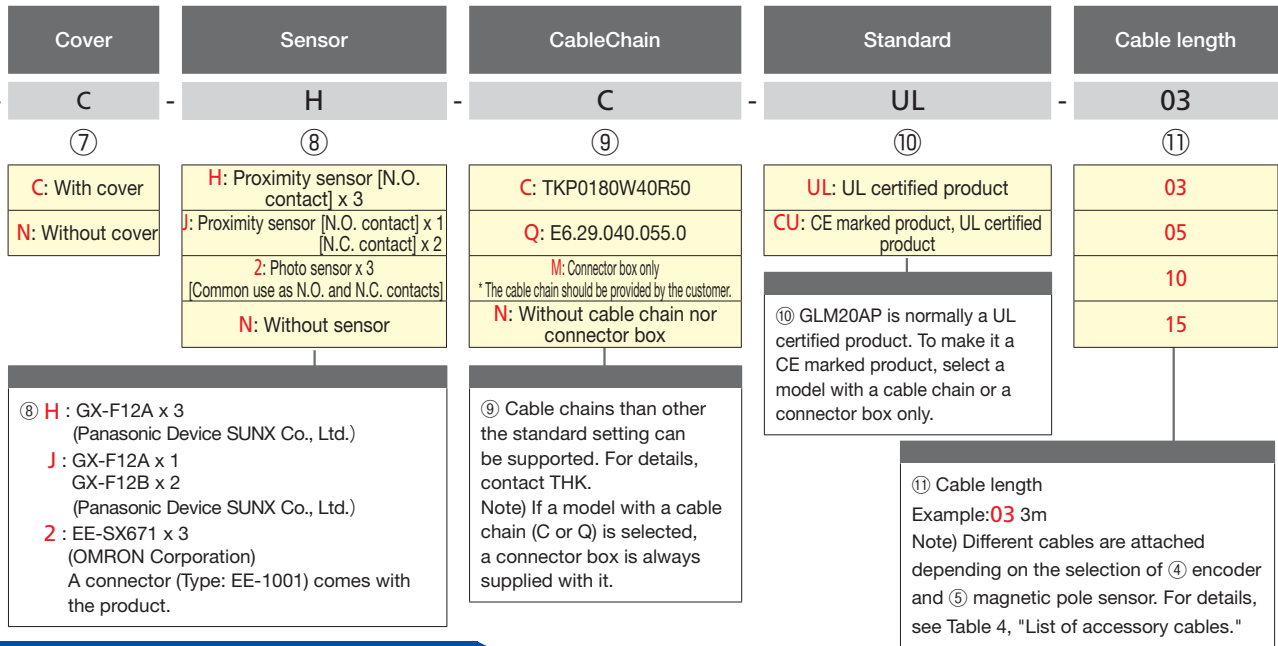

Model configuration example

GLM20AP – S – 0490 – R01K – N – TDP20 – C – N – C – UL – 03

GLM20AP-S

- Stroke 490 mm
- With cover
- Encoder resolution 1 μm



Cable

- Length 3 m



Cable image

Driver

- Driver TDP



Table 4. List of accessory cables

④ Encoder/resolution	⑤ Magnetic pole sensor	Motor cable	Encoder/magnetic pole sensor cable	Origin detector cable	Cable between interpolator/magnetic pole sensor and driver	Cable between interpolator and driver
R01K/R500/R100	J: With magnetic pole sensor	KDK-**-CU	KJET-**-CU	—	—	—
R01K/R500/R100	N: Without magnetic pole sensor		KET-**-CU	—	—	—
H01K	J: With magnetic pole sensor		KHET-**-CU	—	—	—
H01K	N: Without magnetic pole sensor		KEK-**-CU	—	—	—
G10K/G05K	J: With magnetic pole sensor		CK-**-	CE09-**-	KSJT-**-CU	-
G10K/G05K	N: Without magnetic pole sensor		CK-**-	CE09-**-	-	KSET-01-CU

Note) For the actual cable length, check the GLM20AP system configuration diagram (-> P9 to 10).

Detailed content pages

④ Motor type	P.7 to 8	Basic Specifications, Thrust/Speed Characteristics
⑤ Stroke	P.11 to 16	Dimension Diagram
⑥ Encoder/resolution	P.7	Basic Specifications
⑦ Driver	P.5, P.21	Model Configurations, Driver Basic Specifications
⑧ Sensor	P.17	Dimensions at Sensor Installation
⑨ Cable chain	P.18	Dimensions at Cable Chain Installation
⑩ Standard	P.38	Glossary
⑪ Cable length	P.9 to 10	System Configuration

Driver

* GLM20AP consists of an actuator as the main body and a driver TDP provided with it.

If a driver TDP to be used for maintenance is needed, please order it with the following model number.

$$\frac{\text{TDP}}{\textcircled{1}} - \frac{\text{045CU}}{\textcircled{2}} - \frac{\text{200AC}}{\textcircled{3}} - \frac{\text{GA20SU}}{\textcircled{4}} - \frac{\text{1U}}{\textcircled{5}} - \frac{\text{N}}{\textcircled{6}}$$

① Model number	TDP
② Capacity	045CU: 450 W (For S type motor) 075CU: 750 W (For M type motor) 100CU: 1 kW (For L type motor)
③ Input power	100AC: Single/three 100 VAC 200AC: Single/three-phase 200 VAC * The 1-kW capacity specifications support only the input power of three-phase 200 VAC.
④ Motor type	GA20SU : GLM20AP S type GA20MU : GLM20AP M type GA20LU : GLM20AP L type
⑤ Resolution (numeric value + unit)	10U : 10.0 μm 5U : 5.0 μm 1U : 1.0 μm 500N : 0.5 μm 100N : 0.1 μm
⑥ Magnetic pole sensor	N: Without magnetic pole sensor J : With magnetic pole sensor

Cable

* GLM20AP consists of an actuator as the main body and a motor cable, encoder cable, and magnetic pole sensor cable provided with it.

If a cable to be used for maintenance is needed, please order it with the following model number according to the specifications of the linear encoder.

● Case of specifications of optical linear encoder (RENISHAW Inc.)

$$\frac{\text{K}}{\textcircled{1}} \frac{\text{DK}}{\textcircled{2}} - \frac{\text{03}}{\textcircled{3}} - \text{CU}$$

① Symbol	K
② Type	DK : Motor cable (Standard cable length: 3 m, 5 m, 10 m, 15 m) ET : Encoder cable (Standard cable length: 3 m, 5 m, 10 m, 15 m) JET : Encoder/magnetic pole sensor cable (Standard cable length: 3 m, 5 m, 10 m, 15 m)
③ Cable length	03: 3 m, 05: 5 m, 10: 10 m, 15: 15 m * Contact THK if a cable with length other than the standard length is needed.

● Case of specifications of optical linear encoder (HEIDENHAIN Inc.)

$$\frac{\text{K}}{\textcircled{1}} \frac{\text{DK}}{\textcircled{2}} - \frac{\text{03}}{\textcircled{3}} - \text{CU}$$

① Symbol	K
② Type	DK : Motor cable (Standard cable length: 3 m, 5 m, 10 m, 15 m) EK : Encoder cable (Standard cable length: 3 m, 5 m, 10 m, 15 m) HET: Encoder/magnetic pole sensor cable (Standard cable length: 3 m, 5 m, 10 m, 15 m)
③ Cable length	03: 3 m, 05: 5 m, 10: 10 m, 15: 15 m * Contact THK if a cable with length other than the standard length is needed.

● Case of specifications of magnetic linear encoder (Magnescale Co., Ltd.)

K DK - 03 - CU
 ① ② ③

① Symbol	K
② Type	DK : Motor cable (Standard cable lengths: 3 m, 5 m, 10 m, 15 m) SET : Cable between interpolator and driver (Standard cable length: 1 m) SJT : Cable between magnetic pole sensor/interpolator and driver (Standard length of cable between interpolator and driver: 1 m commonly) (Standard length of cable between magnetic pole sensor and driver: 3 m, 5 m, 10 m, and 15 m)
③ Cable length	03: 3 m, 05: 5 m, 10: 10 m, 15: 15 m * Contact THK if a cable with length other than the standard length is needed.

C K - 03
 ① ② ③

① Symbol	C
② Type	K : Encoder cable (Standard cable length: 3 m, 5 m, 10 m, 15 m) E09 : Origin detector cable (Standard cable length: 3 m, 5 m, 10 m, 15 m)
③ Cable length	03: 3 m, 05: 5 m, 10: 10 m, 15: 15 m * Contact THK if a cable with length other than the standard length is needed.

Setup tool

● Digital operator

D - CON2
 ①

① Type	D-CON2: Digital operator (-> P.20)
--------	------------------------------------

Note) D-CON2 is not provided with the actuator or the driver TDP. Please order them with the above model number.

● Communication cable (PC communication cable RS-232C when using D-Assist)

K232 - 01
 ①

① Cable length	01: 1 m
----------------	---------

Note) D-Assist Ver.2 is a required tool to change the driver TDP parameter settings. The use of USB cables on the driver TDP is supported. For details of USB cables, contact THK. Communication cables are not provided with the actuator or the driver TDP. Please order them with the above model number. For details about D-Assist Ver.2, see P.20.

Encoder adjustment device

APS27
 ①

① Type	APS27: Encoder adjustment device (-> P.20)
--------	--

Note) APS27 is an encoder adjustment device used to evaluate the installation tolerance of LIDA277 with TTL interface (HEIDENHAIN Inc.). Although the encoder has been adjusted at the shipment of the actuator, it is needed for readjustment during maintenance and inspection, etc.

GLM20AP

Basic Specifications

Item		Motor type	S type										M type										L Type				
Adapted driver	TDP	Capacity	450W										750W										1kW				
		Main circuit power voltage	Single/three-phase 200 VAC					AC100V					Single/three-phase 200 VAC					AC100V					Three-phase 200 VAC				
		Control circuit power voltage	Single 200 VAC					AC100V					Single 200 VAC					AC100V					Single 200 VAC				
Maximum thrust ^{*1} [N]			336					325					618					562					954				
Rated thrust ^{*1} [N]			118					113					220					197					344				
Resolution [μm]			10.0	5.0	1.0	0.5	0.1	10.0	5.0	1.0	0.5	0.1	10.0	5.0	1.0	0.5	0.1	10.0	5.0	1.0	0.5	0.1	10.0	5.0	1.0	0.5	0.1
Maximum speed ^{*2} [m/s]			3.0		1.5		0.3		2.0		1.5		0.3		3.0		1.5		0.3		2.0		1.5		0.3		
Repetitious positioning accuracy [μm]			±10	±5	±1		±10	±5	±1		±10	±5	±1		±10	±5	±1		±10	±5	±1		±10	±5	±1		
Maximum transportable weight ^{*3} [kg]			46.1					41.0					86.1					71.0					134.6				
Assumed transportable weight ^{*4} [kg]			7.7					6.0					15.0					11.0					24.5				

*1 When the average temperature of the armature winding is 90°C under an ambient temperature of 20°C.

*2 The maximum speed varies depending on the resolution.

Example: The maximum speed is 0.3 m/s when the motor type is S, the driver model number is TDP-045CU-200AC-GA20SU, and the resolution is 0.1μm.

*3 The specifications of the operating speed, acceleration/deceleration, etc. are limited by the load weight. See "Selection Method for Linear Motors" on P.511 to 520.

The maximum transportable weight is a weight that can be driven at an approximate acceleration of 0.5 G.

*4 The assumed transportable weight is a weight that can be driven for a certain stroke at a duty ratio of 50 % with an approximate acceleration of 2 G and a maximum operating speed of 1.0 m/s.

Depending on the operating conditions, the movable weight may change under the influence of the thrust and speed characteristics.



Thrust/Speed Characteristics

[200 VAC Specifications]

Motor type: S type
Driver: TDP-045CU-200AC-GA20SU

Motor type: M type
Driver: TDP-075CU-200AC-GA20MU

Motor type: L type
Driver: TDP-100CU-200AC-GA20LU

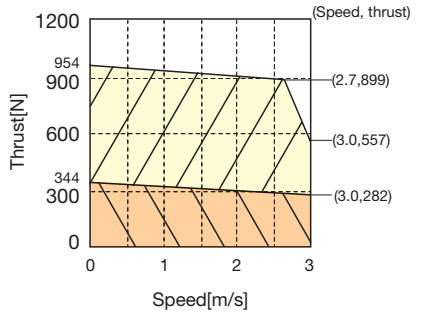
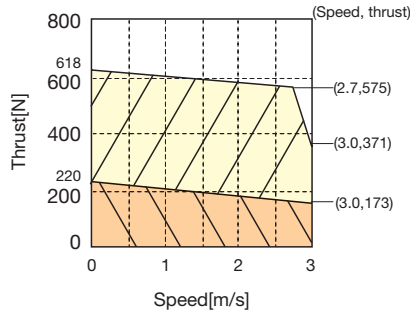
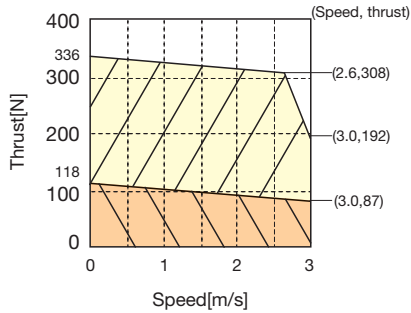

Maximum area
 Continuous area

[100 VAC Specifications]

Motor type: S type
Driver: TDP-045CU-100AC-GA20SU

Motor type: M type
Driver: TDP-075CU-100AC-GA20MU

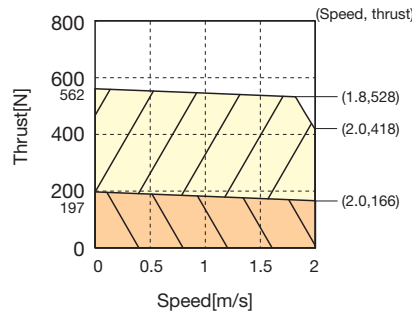
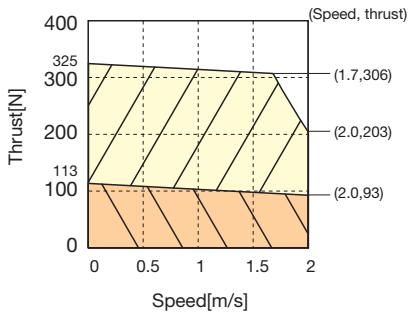

Note) The thrust and speed characteristics shown above are values that take into consideration the sliding resistance component of the LM guide due to the slider attractive force and slider weight.

Transportable Weight and Acceleration

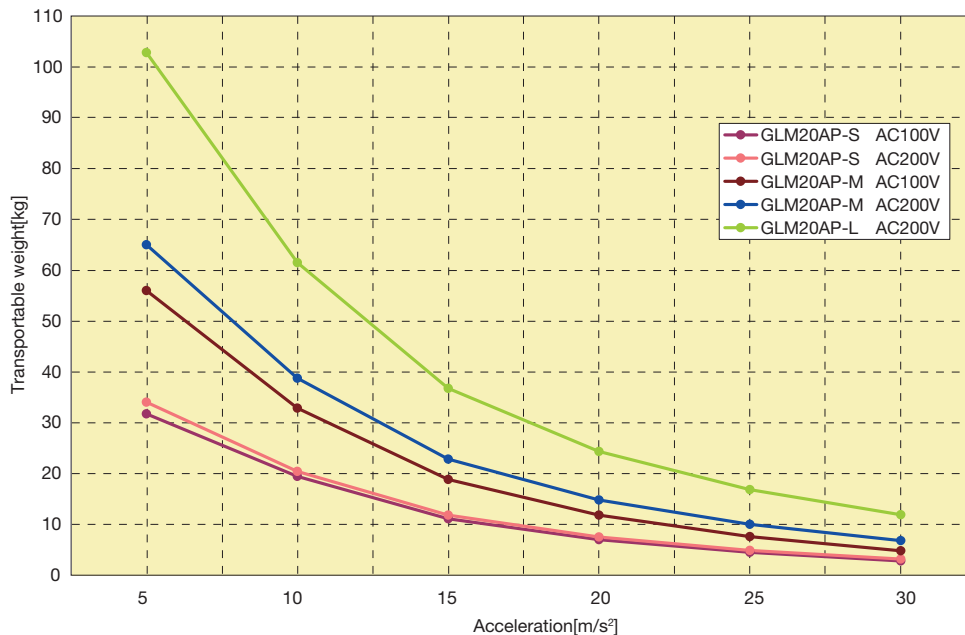

Note) At a maximum operating speed of 1.0 m/s, the unit can be driven for a certain stroke at a duty ratio of 50 % at this weight. For details about selection, see "Selection Method for Linear Motors" on P.511 to 520.

System Configuration

- Driver TDP specifications (optical linear encoder manufactured by RENISHAW Inc./HEIDENHAIN Inc.)
Motor type: S, M, L type

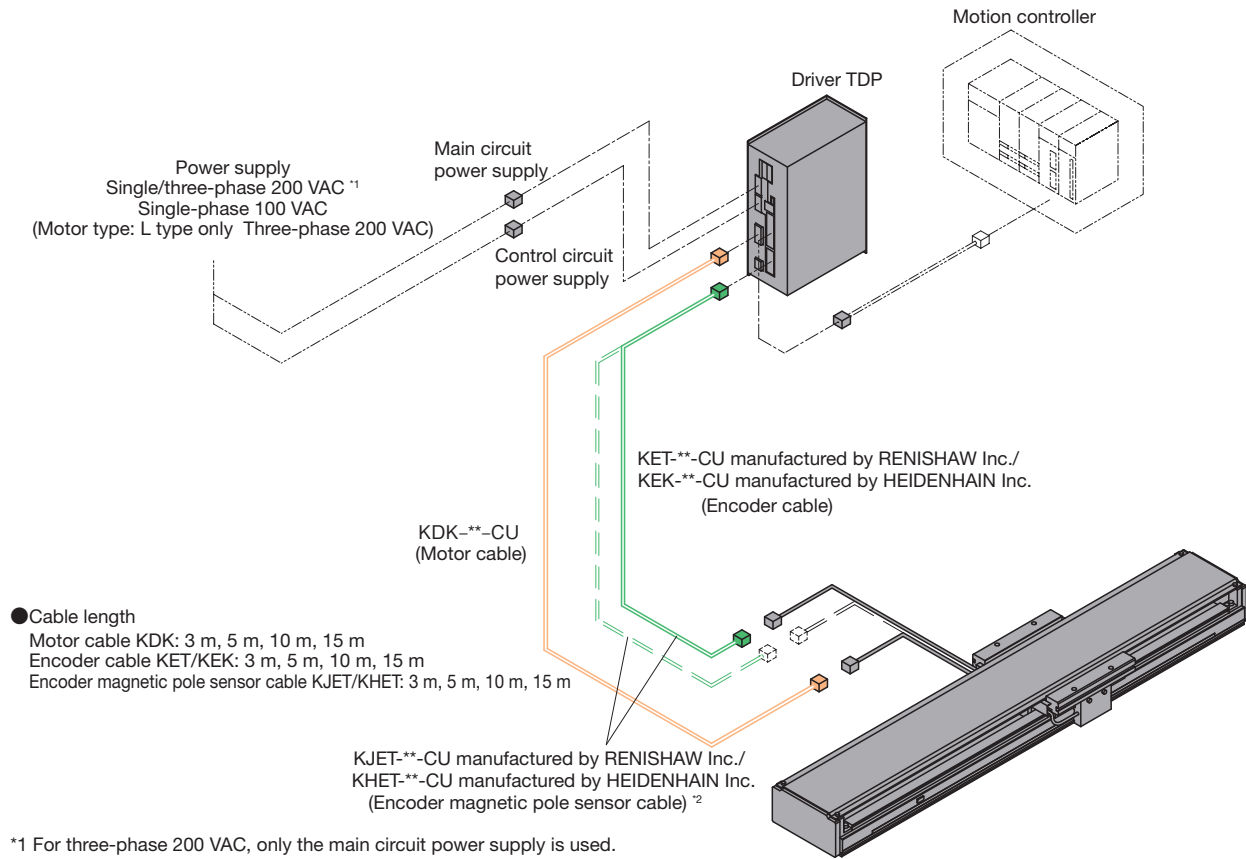

● Driver TDP specifications (magnetic linear encoder manufactured by
Magnescale Co., LTD.)
Motor type: S, M, L type

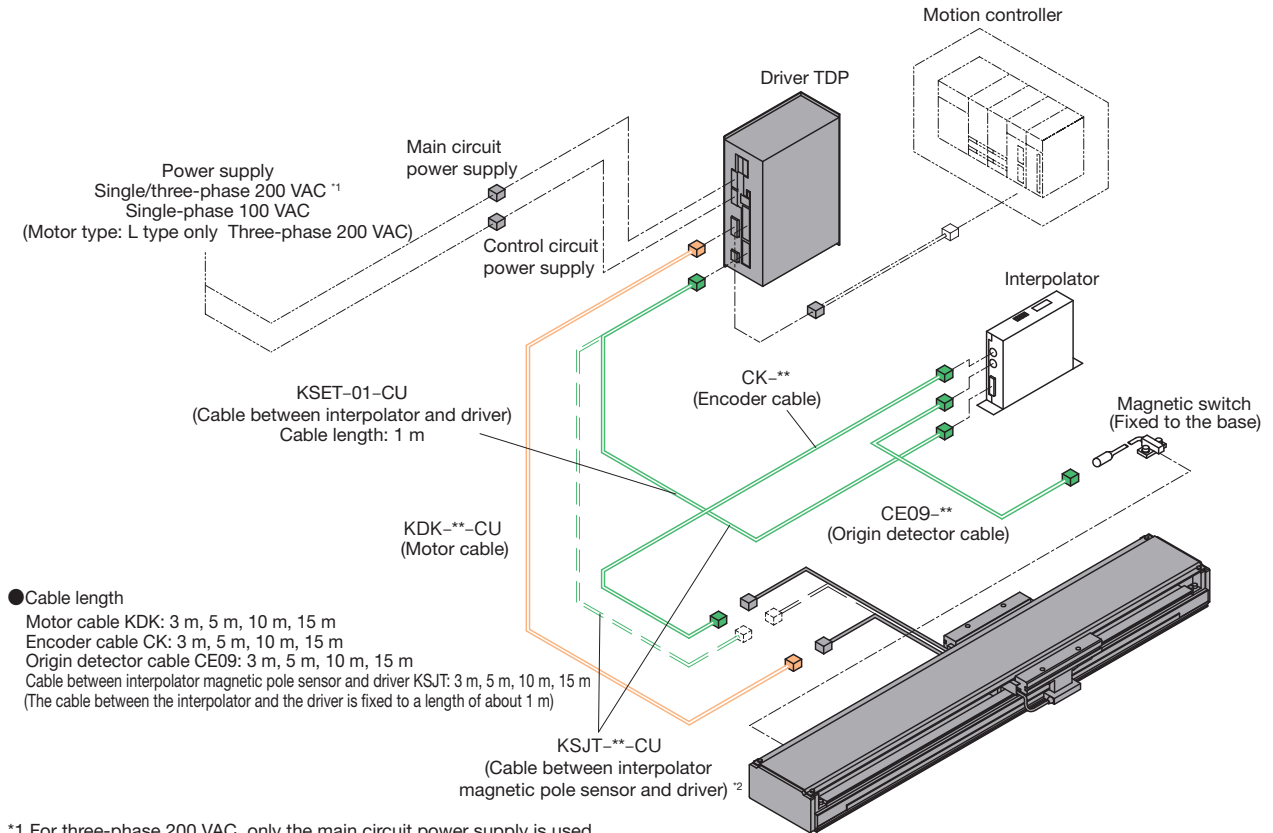

*1 For three-phase 200 VAC, only the main circuit power supply is used.

*2 For the cable with a magnetic pole sensor, the dashed lines are involved.

GLM20AP

S Type Flat Type with Core

Height: 80 mm, Stroke: 130 to 2650 mm



Dimension Diagram

● Specifications of optical linear encoder (RENISHAW Inc.)

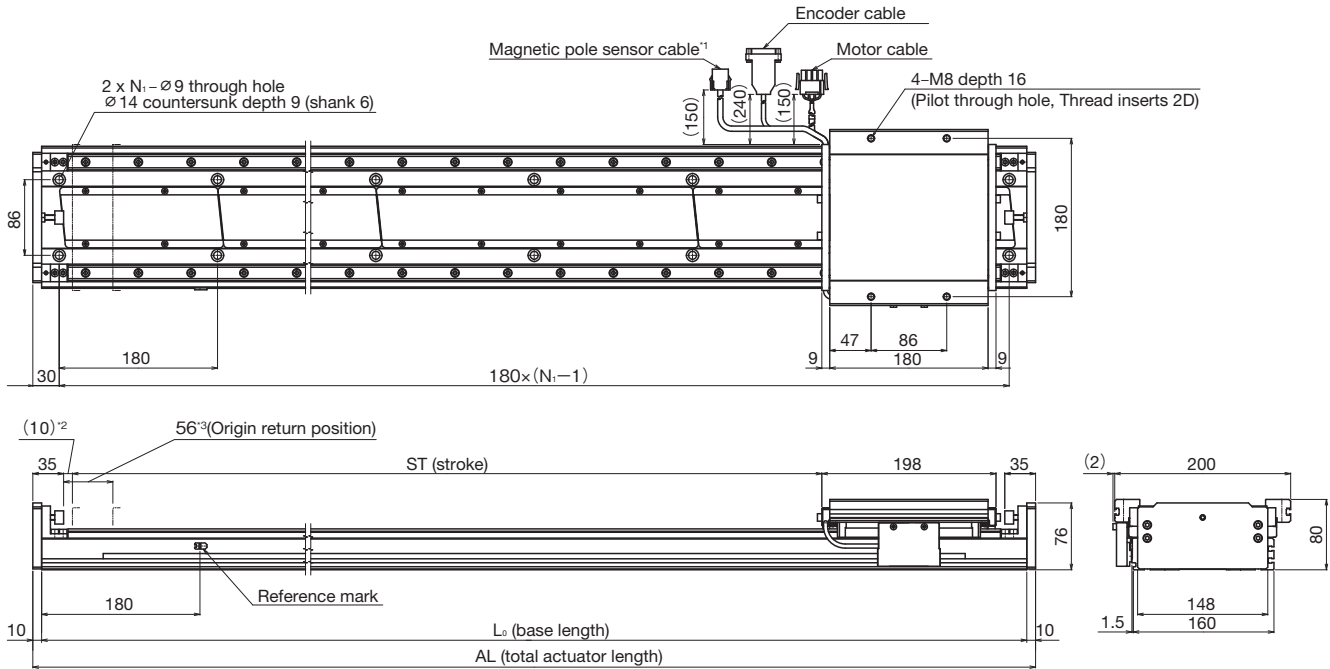

*1 Note that the magnetic pole sensor cable is not provided with the model without a magnetic pole sensor.

*2 Shows stroke margin between hard stop stroke and rated stroke. Actual stroke margin must be determined from coast stroke considering carrying load that can safely stop from maximum operation speed.

*3 The origin return position if the reference mark is used.

● Specifications of optical linear encoder (HEIDENHAIN Inc.)

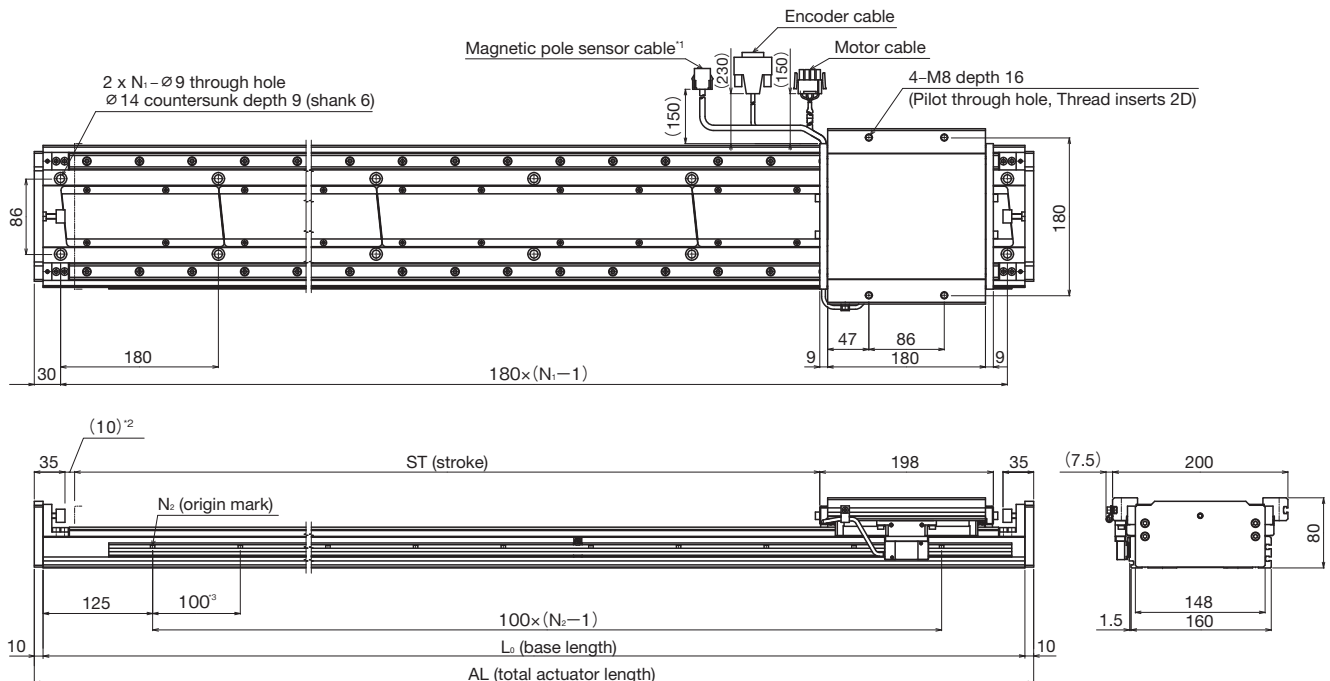

*1 Note that the magnetic pole sensor cable is not provided with the model without a magnetic pole sensor.

*2 Shows stroke margin between hard stop stroke and rated stroke. Actual stroke margin must be determined from coast stroke considering carrying load that can safely stop from maximum operation speed.

*3 An origin is output every 100 mm. Select an origin position to be actually used using an external sensor.

Dimension Diagram

Specifications of magnetic linear encoder (Magnescale Co., Ltd.)

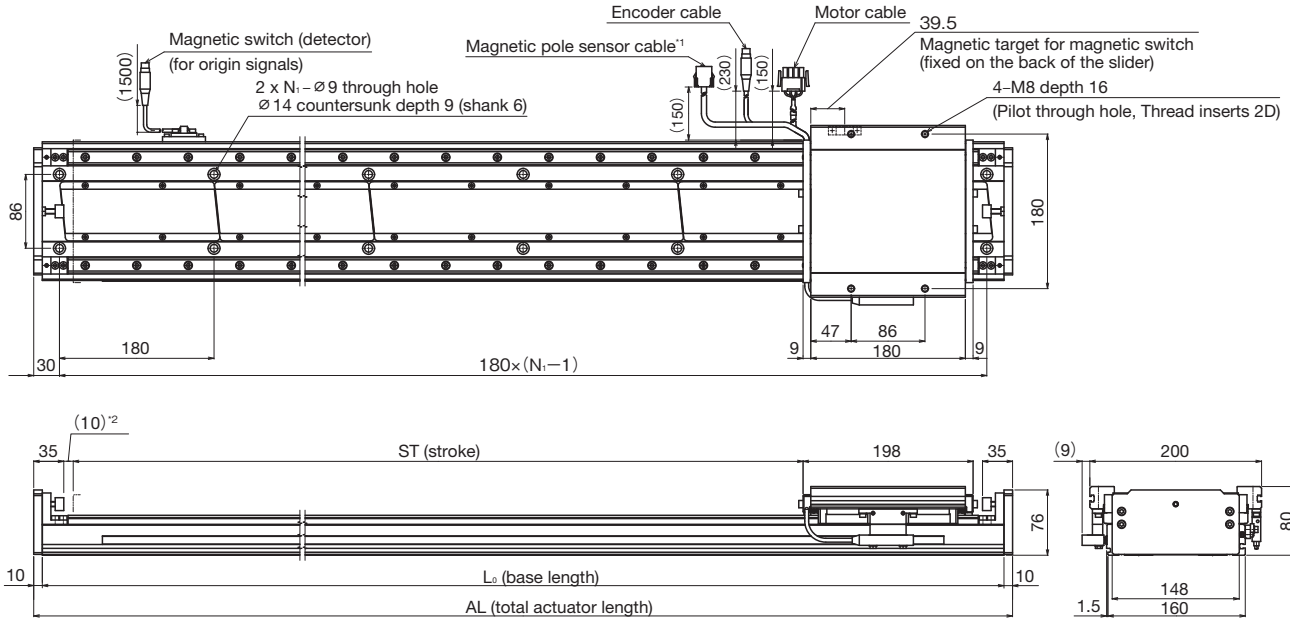

*1 Note that the magnetic pole sensor cable is not provided with the model without a magnetic pole sensor.

*2 Shows stroke margin between hard stop stroke and rated stroke. Actual stroke margin must be determined from coast stroke considering carrying load that can safely stop from maximum operation speed.

T Slot Dimensions

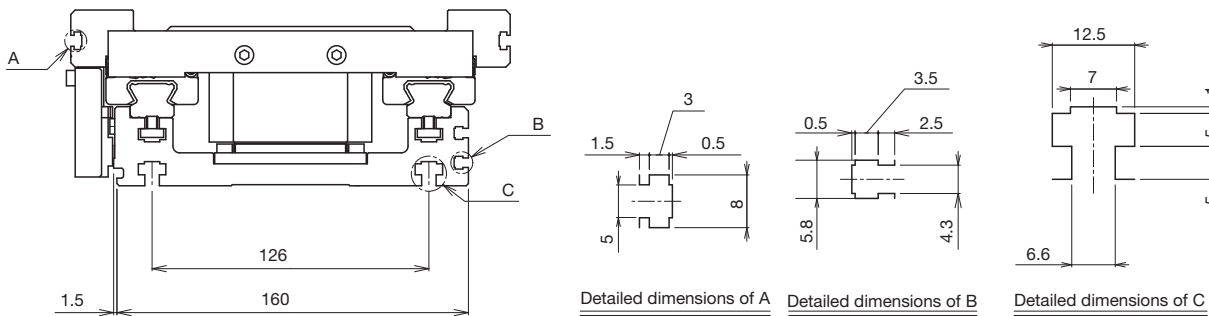

Detailed Dimensions

GLM20AP-S-		0130 ^{*1}	0310	0490	0670	0850	1030	1210	1390	1570	1750	1930	2110	2290	2470	2650
Stroke [mm]	ST	130	310	490	670	850	1030	1210	1390	1570	1750	1930	2110	2290	2470	2650
(Stroke between mechanical stoppers) [mm]		(152)	(332)	(512)	(692)	(872)	(1052)	(1232)	(1412)	(1592)	(1772)	(1952)	(2132)	(2312)	(2492)	(2672)
Base length [mm]	L_0	400	580	760	940	1120	1300	1480	1660	1840	2020	2200	2380	2560	2740	2920
Total actuator length [mm]	AL	420	600	780	960	1140	1320	1500	1680	1860	2040	2220	2400	2580	2760	2940
Number of installation holes per column	N_1	3	4	5	6	7	8	9	10	11	12	13	14	15	16	17
Number of origin marks (HEIDENHAIN Inc. only)	N_2	1	3	4	6	8	10	11	13	15	17	19	21	22	24	26
Slider weight ^{*2} [kg]	m2	5.3														
Base weight [kg]	m3	6.3	8.9	11.6	14.3	16.9	19.6	22.2	24.9	27.6	30.2	32.9	35.6	38.2	40.9	43.5
Main unit weight ^{*3} [kg]	M	11.9	14.7	17.5	20.3	23.1	25.9	28.7	31.5	34.3	37.1	39.9	42.7	45.5	48.3	51.1

*1 Due to a short stroke, some of the base installation holes in the center may be unusable. In this case, use the base installation nuts (->P.17) for fixing on the T slot.

*2 The slider weight is the value when it is equipped with a magnetic pole sensor. Without a magnetic pole sensor, the slider weight is -0.2 kg.

*3 The main unit weight is the value when it is equipped with a magnetic pole sensor and a cover.

GLM20AP

M Type Flat Type with Core

Height: 80 mm, Stroke: 160 to 2500 mm



Dimension Diagram

● Specifications of optical linear encoder (RENISHAW Inc.)

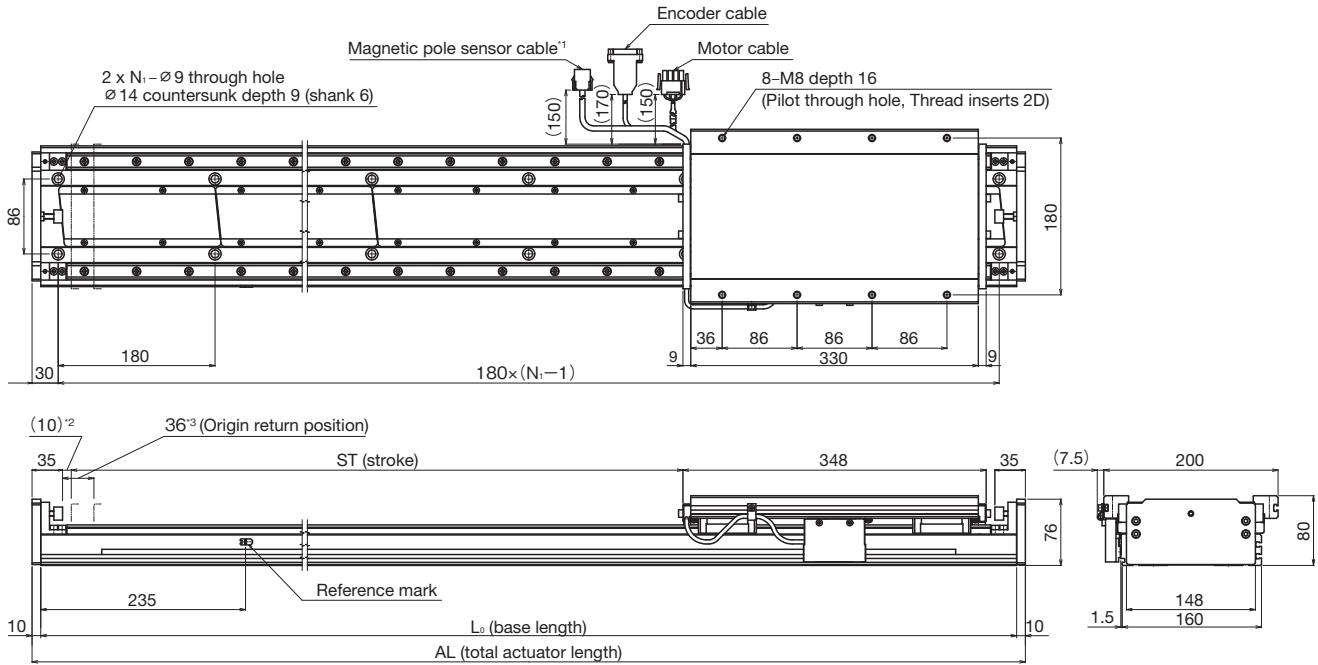

*1 Note that the magnetic pole sensor cable is not provided with the model without a magnetic pole sensor.

*2 Shows stroke margin between hard stop stroke and rated stroke. Actual stroke margin must be determined from coast stroke considering carrying load that can safely stop from maximum operation speed.

*3 The origin return position if the reference mark is used.

● Specifications of optical linear encoder (HEIDENHAIN Inc.)

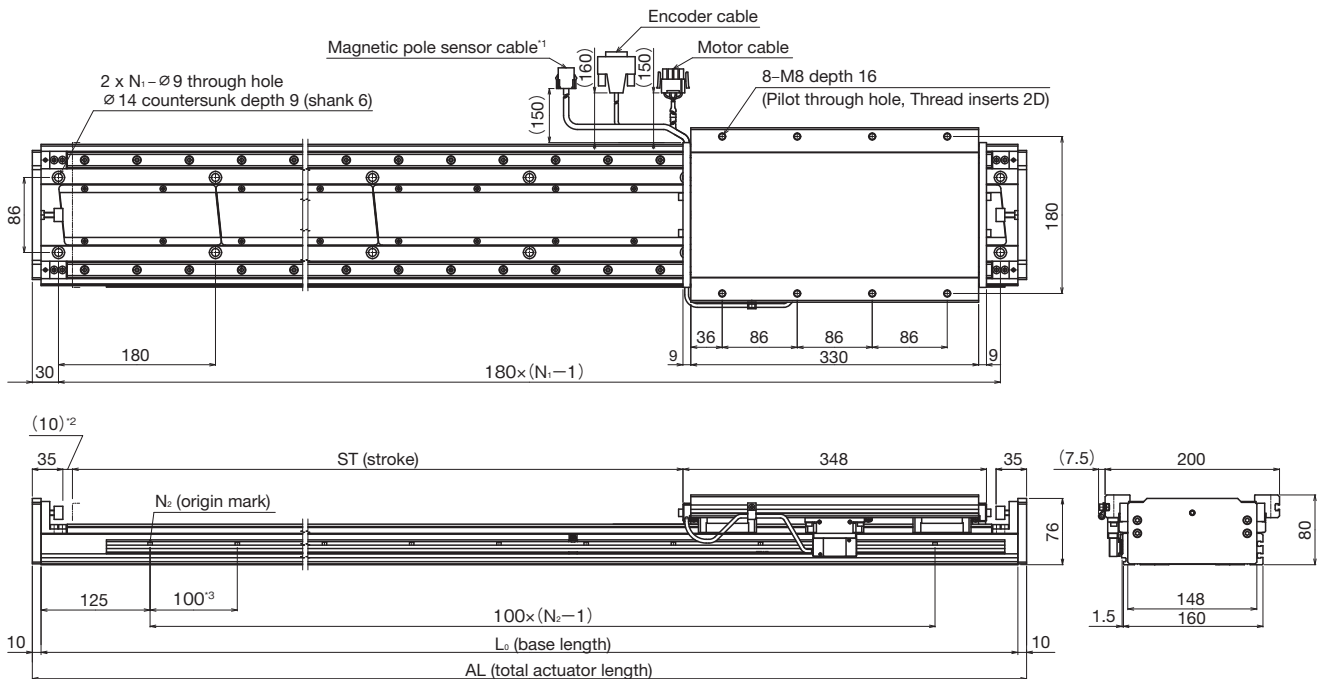

*1 Note that the magnetic pole sensor cable is not provided with the model without a magnetic pole sensor.

*2 Shows stroke margin between hard stop stroke and rated stroke. Actual stroke margin must be determined from coast stroke considering carrying load that can safely stop from maximum operation speed.

*3 An origin is output every 100 mm. Select an origin position to be actually used using an external sensor.

Dimension Diagram

Specifications of magnetic linear encoder (Magnescale Co., Ltd.)

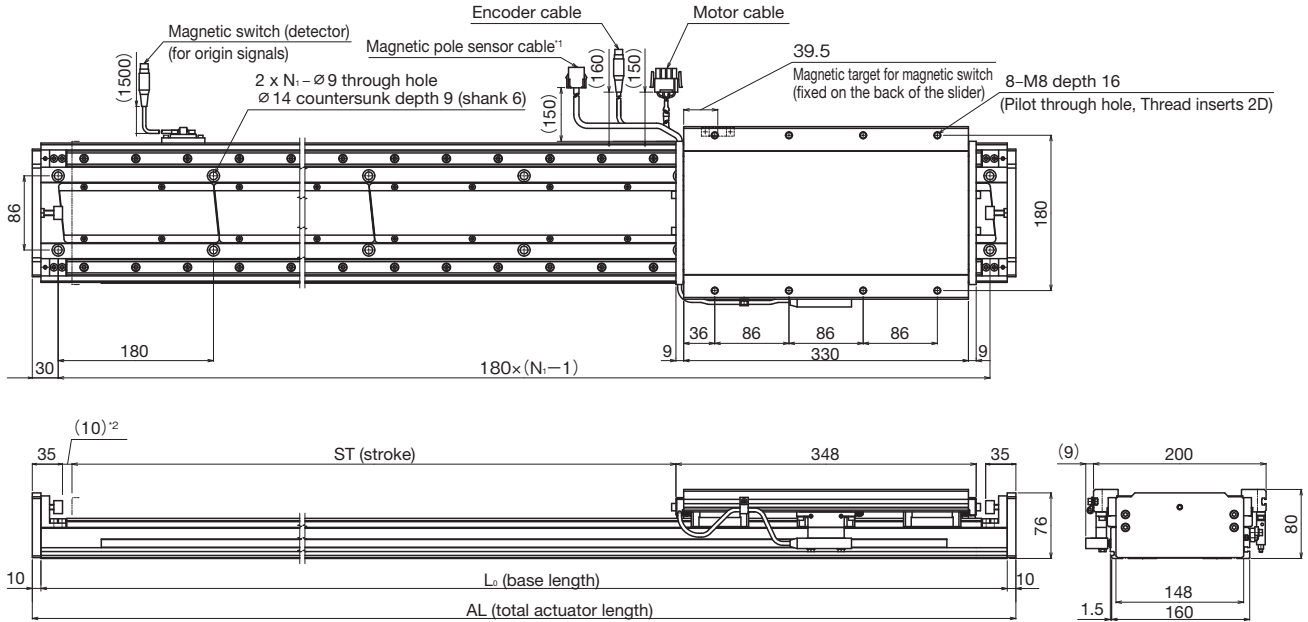

*1 Note that the magnetic pole sensor cable is not provided with the model without a magnetic pole sensor.

*2 Shows stroke margin between hard stop stroke and rated stroke. Actual stroke margin must be determined from coast stroke considering carrying load that can safely stop from maximum operation speed.

T Slot Dimensions

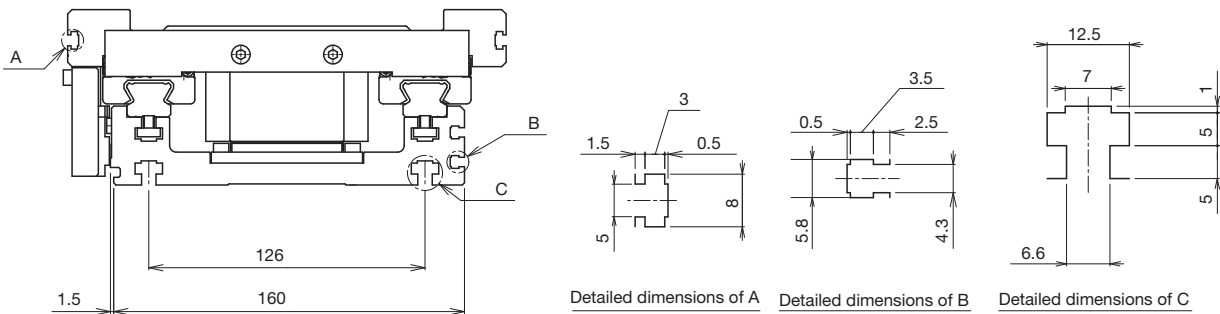

Detailed Dimensions

GLM20AP-M-		0160	0340	0520	0700	0880	1060	1240	1420	1600	1780	1960	2140	2320	2500
Stroke [mm]	ST	160	340	520	700	880	1060	1240	1420	1600	1780	1960	2140	2320	2500
(Stroke between mechanical stoppers) [mm]		(182)	(362)	(542)	(722)	(902)	(1082)	(1262)	(1442)	(1622)	(1802)	(1982)	(2162)	(2342)	(2522)
Base length [mm]	L_0	580	760	940	1120	1300	1480	1660	1840	2020	2200	2380	2560	2740	2920
Total actuator length [mm]	AL	600	780	960	1140	1320	1500	1680	1860	2040	2220	2400	2580	2760	2940
Number of installation holes per column	N_1	4	5	6	7	8	9	10	11	12	13	14	15	16	17
Number of origin marks (HEIDENHAIN Inc. only)	N_2	2	4	6	7	9	11	13	15	16	18	20	22	24	25
Slider weight ^{*1} [kg]	m2	9.1													
Base weight [kg]	m3	8.9	11.6	14.3	16.9	19.6	22.2	24.9	27.6	30.2	32.9	35.6	38.2	40.9	43.5
Main unit weight ^{*2} [kg]	M	18.5	21.3	24.1	26.9	29.7	32.5	35.3	38.1	40.9	43.7	46.5	49.3	52.1	54.9

*1 The slider weight is the value when it is equipped with a magnetic pole sensor. Without a magnetic pole sensor, the slider weight is -0.2 kg.

*2 The main unit weight is the value when it is equipped with a magnetic pole sensor and a cover.

GLM20AP

L Type Flat Type with Core

Height: 80 mm, Stroke: 200 to 2360mm



Dimension Diagram

● Specifications of optical linear encoder (RENISHAW Inc.)

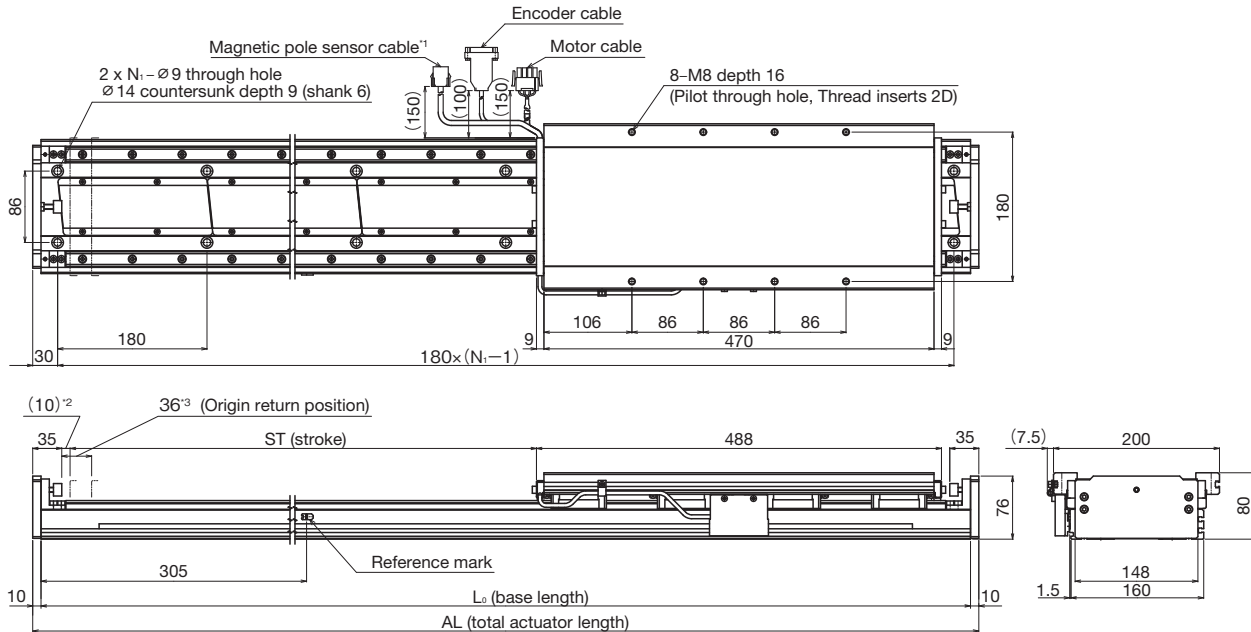

*1 Note that the magnetic pole sensor cable is not provided with the model without a magnetic pole sensor.

*2 Shows stroke margin between hard stop stroke and rated stroke. Actual stroke margin must be determined from coast stroke considering carrying load that can safely stop from maximum operation speed.

*3 The origin return position if the reference mark is used.

● Specifications of optical linear encoder (HEIDENHAIN Inc.)

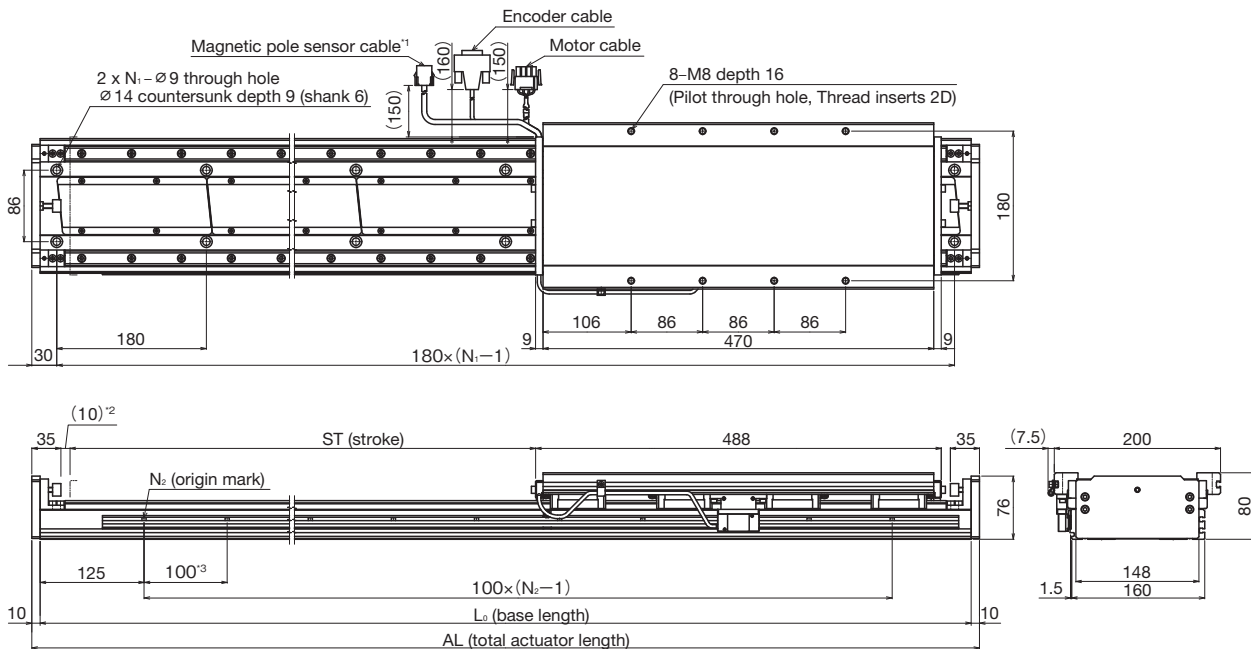

*1 Note that the magnetic pole sensor cable is not provided with the model without a magnetic pole sensor.

*2 Shows stroke margin between hard stop stroke and rated stroke. Actual stroke margin must be determined from coast stroke considering carrying load that can safely stop from maximum operation speed.

*3 An origin is output every 100 mm. Select an origin position to be actually used using an external sensor.

Dimension Diagram

Specifications of magnetic linear encoder (Magescale Co., Ltd.)

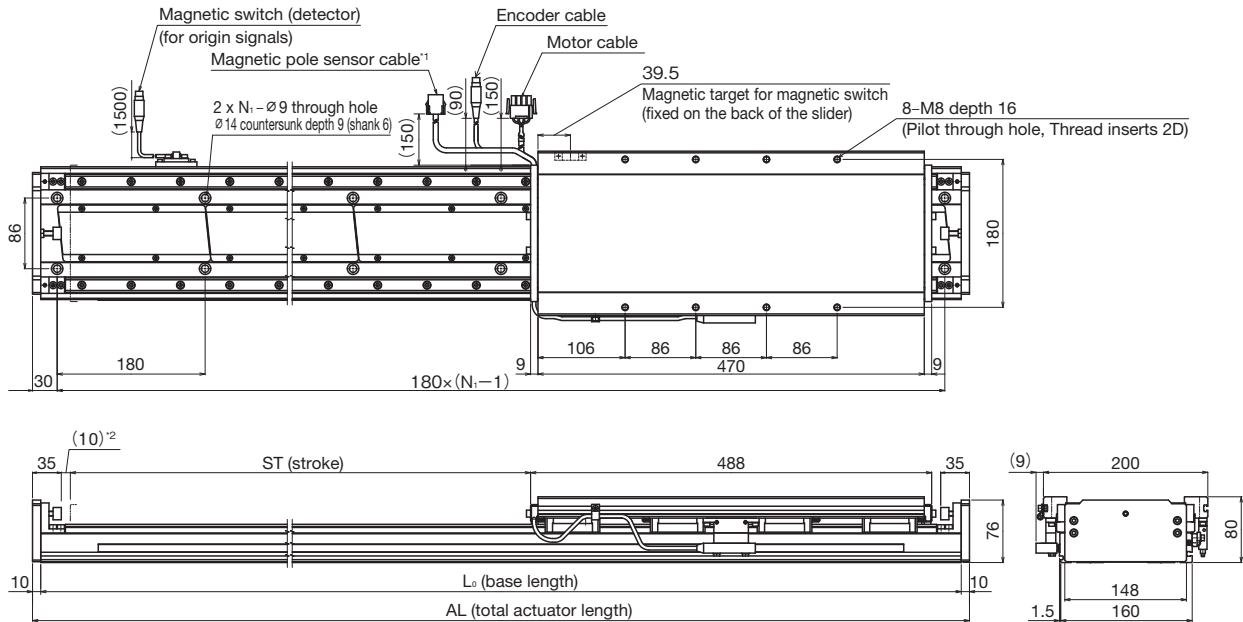

*1 Note that the magnetic pole sensor cable is not provided with the model without a magnetic pole sensor.

*2 Shows stroke margin between hard stop stroke and rated stroke. Actual stroke margin must be determined from coast stroke considering carrying load that can safely stop from maximum operation speed.

T Slot Dimensions

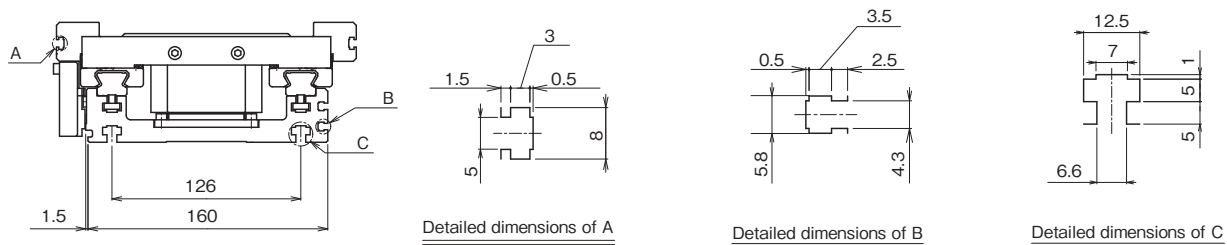

Detailed Dimensions

GLM20AP-L-		0200 ^{*1}	0380	0560	0740	0920	1100	1280	1460	1640	1820	2000	2180	2360
Stroke [mm]	ST	200	380	560	740	920	1100	1280	1460	1640	1820	2000	2180	2360
(Stroke between mechanical stoppers) [mm]		(222)	(402)	(582)	(762)	(942)	(1122)	(1302)	(1482)	(1662)	(1842)	(2022)	(2202)	(2382)
Base length [mm]	L ₀	760	940	1120	1300	1480	1660	1840	2020	2200	2380	2560	2740	2920
Total actuator length [mm]	AL	780	960	1140	1320	1500	1680	1860	2040	2220	2400	2580	2760	2940
Number of installation holes per column	N ₁	5	6	7	8	9	10	11	12	13	14	15	16	17
Number of origin marks (HEIDENHAIN Inc. only)	N ₂	2	4	6	8	9	11	13	15	17	18	20	22	24
Slider weight ^{*2} [kg]	m2	12.9												
Base weight [kg]	m3	11.6	14.3	16.9	19.6	22.2	24.9	27.6	30.2	32.9	35.6	38.2	40.9	43.5
Main unit weight ^{*3} [kg]	M	25.1	27.9	30.7	33.5	36.3	39.1	41.9	44.7	47.5	50.3	53.1	55.9	58.7

*1 Due to a short stroke, some of the base installation holes in the center may be unusable. In this case, use the base installation nuts (-> P.17) for fixing on the T slot.

*2 The slider weight is the value when it is equipped with a magnetic pole sensor. Without a magnetic pole sensor, the slider weight is -0.2 kg.

*3 The main unit weight is the value when it is equipped with a magnetic pole sensor and a cover.

Dimensions at Sensor Installation

Proximity sensor "H", "J"

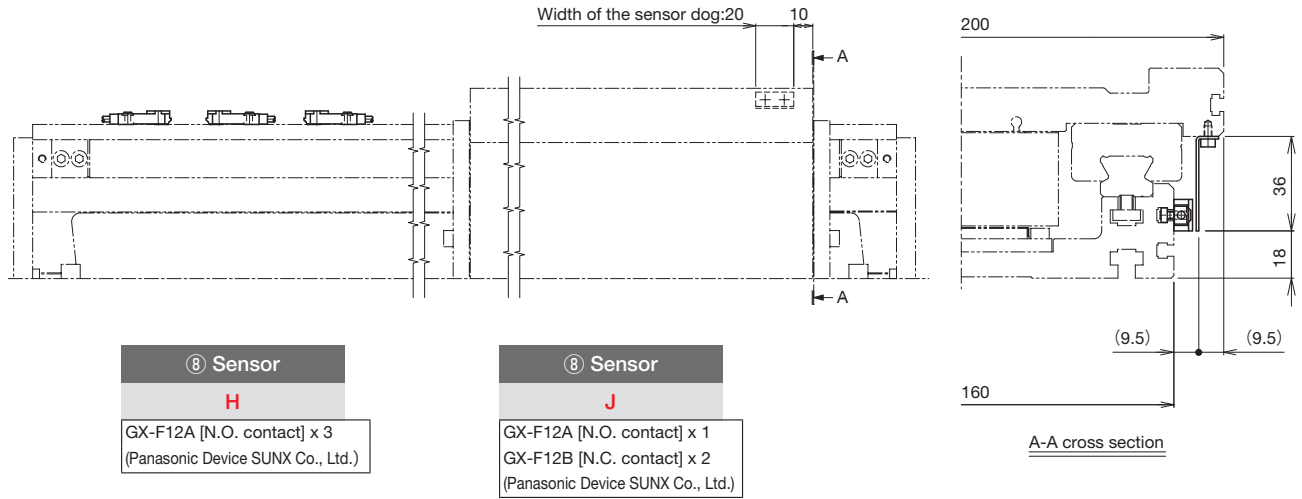
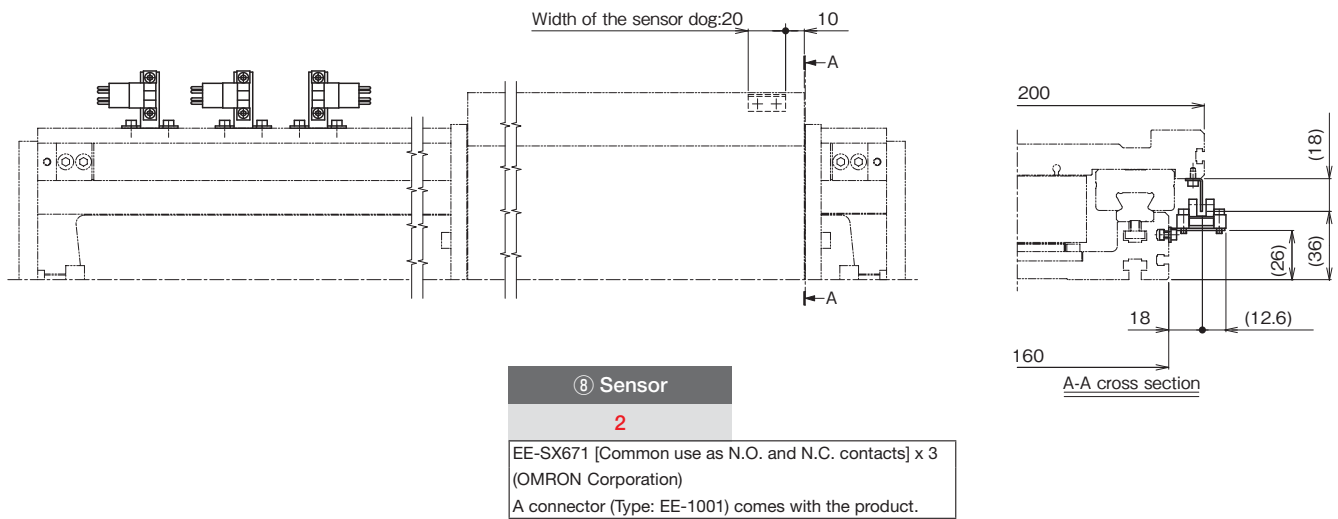
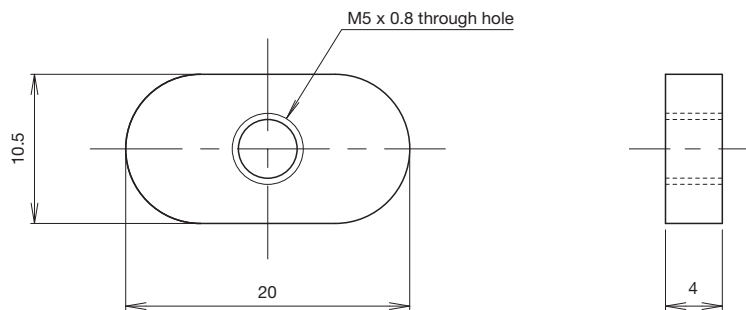

Photo sensor "2"



Outer Dimensions of Base Installation Nuts



Contact THK if base installation nuts is required.

Dimensions at Cable Chain Installation

Connector box "M"

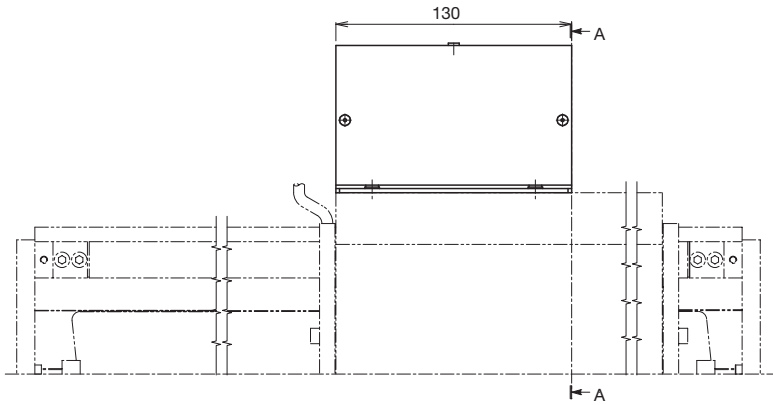

⑨ Cable chain
M
 Connector box only
 * The cable chain should be provided by the customer.

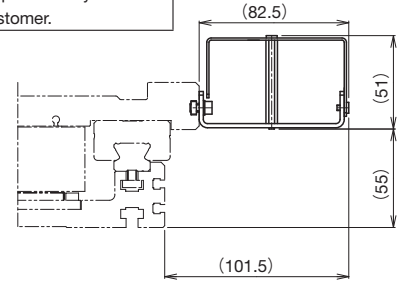

A-A cross section

Cable chain "C"

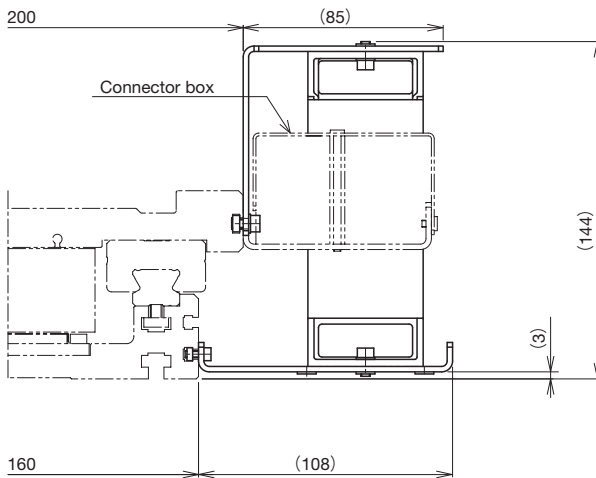

⑨ Cable chain
C
 TKP0180W40R50
 (TSUBAKIMOTO CHAIN CO.)

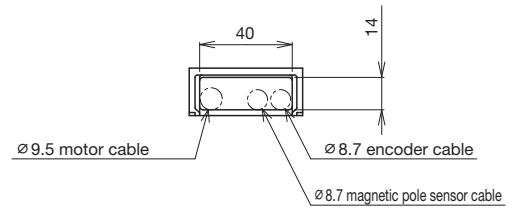

Cable chain cross section

Note) If a model with a cable chain is selected, a connector box is always supplied with it.

Cable chain "Q"

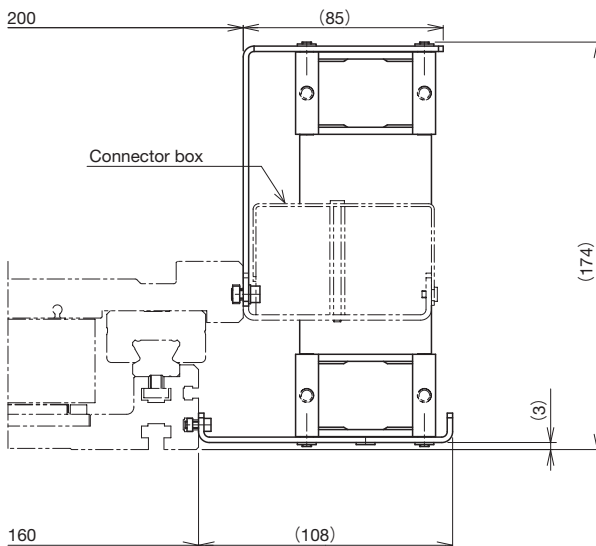

⑨ Cable chain
Q
 E6.29.040.055.0
 (igus K.K.)

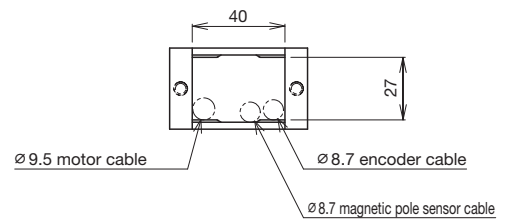

Cable chain cross section

Note) If a model with a cable chain is selected, a connector box is always supplied with it.

Driver TDP Specifically Designed for Linear Motor Drive

Features

1 Auto tuning

Equipped with an auto tuning function. Reduces the time required for adjustment operations.



2 Vibration suppression function during stop

While the linear motor is stopped, vibrations (hunting) specific to the servo motor occur. The vibration suppression function during stop can suppress these vibrations.



3 Easy-to-use setup tools

The PC software D-Assist Ver.2 facilitates the setup of parameters and others.

4 USB communication function

Using the USB2.0 as a communication method to the PC makes the communication speed faster.

Setup Tool

To change parameters for driver TDP, the PC software D-Assist Ver.2 is required.

PC software D-Assist Ver.2

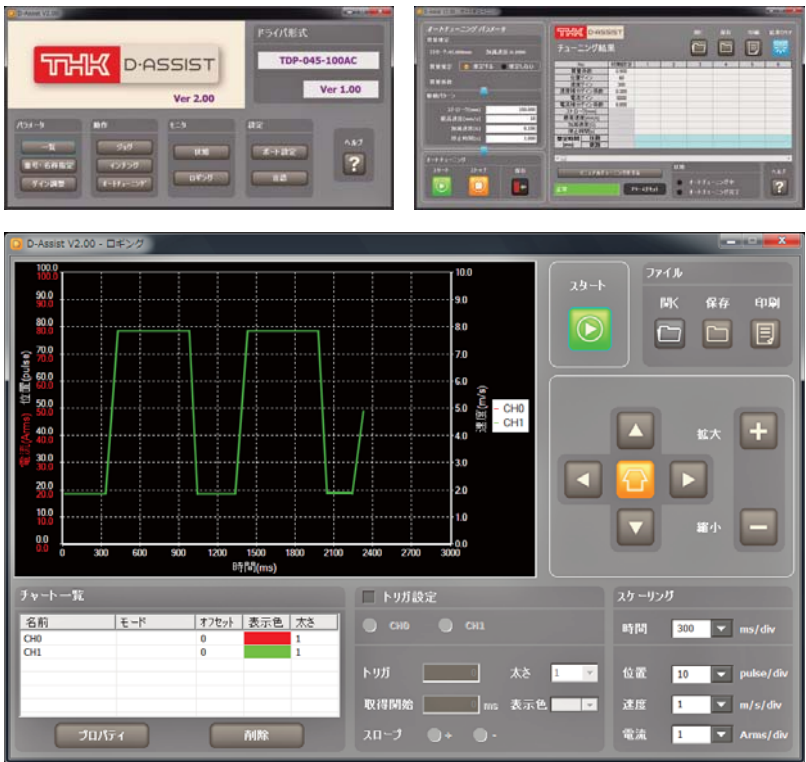

Features

Easy operation
on PC

Parameters can also
be set on your PC.

Functions

- Auto tuning function settings
- Check/change/write/save parameters
- Monitoring (I/O, position, alarm, effective load factor)
- Logging (position/speed/current waveform display)
- Jogging/inching movement
- Set communication speed
- Supported OS: Windows XP, Vista, 7

Note) To use D-Assist, a separately sold PC communication cable K232-01 or a USB cable is required.

USB cable (commercially available product) *

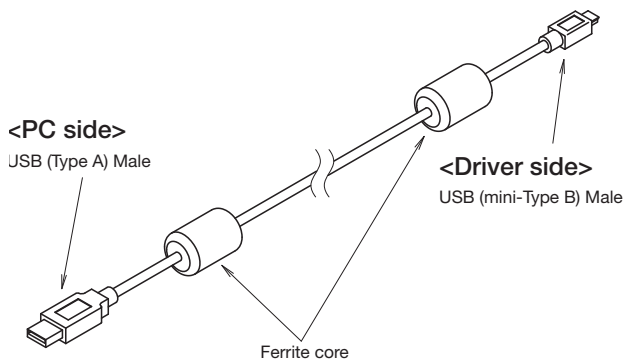



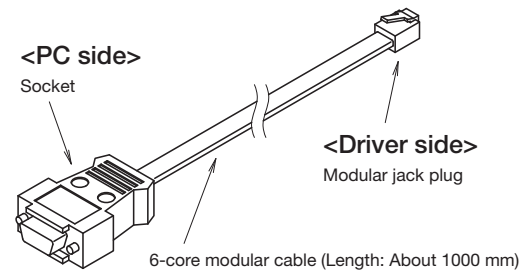



PC communication cable K232-01

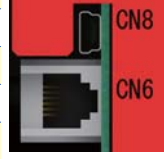

* A commercially available USB cable with a ferrite core should be used.

Specifications (Main Circuit Voltage 100VAC)

Model	Model number		TDP					
	Capacity		450W	750W	450W	750W	1kW	
Model	Appearance							
Input power	Main circuit		100VAC, 50/60Hz (Allowable voltage 90 to 120 V)		Single/three-phase 200 VAC, 50/60 Hz (Allowable voltage 170 to 250V)		Three-phase 200 VAC, 50/60 Hz (Allowable voltage 170 to 250V)	
	Control circuit		100VAC, 50/60Hz (Allowable voltage 90 to 120 V)		Single-phase 200 VAC, 50/60 Hz (Allowable voltage 170 to 250V)			
	Power supply capacity		0.7kVA	0.9kVA	1.4kVA	1.9kVA	2.3kVA	
Control	Number of control axes		One axis					
	Control method		PWM control, sine wave drive method					
	Auto tuning		Settling time emphasis type					
	Position detection	Detection method	Incremental					
		Input signal	Phase A + phase B (pulse)					
	Position control	Command method	Pulse column (sign + pulse column/CW + CCW pulse column/two-phase pulse column with 90° phase difference)					
Input signal		Differential line driver (5 VDC)						
Frequency		Up to 5 MHz						
I/O	Positional signal output		Phases A, B, Z					
	Dedicated input and output	Number of inputs	Seven inputs (servo on, forward/reverse run prohibited, alarm reset, reference pulse inhibit, DB input, location deviation clear)					
		Number of outputs	Six outputs (servo alarm, alarm code (3 bits), positioning completion, servo ready)					
Communication	Serial communication 1 (CN8)	Connecting device	PC software D-Assist					
		Communication method	USB2.0 (Full Speed)					
		Number of ports	USB mini B x 1					
	Serial communication 2 (CN6)	Connecting device	PC software D-Assist, digital operator D-CON2 ^{*1}					
		Communication method	RS-232C					
		Number of ports	RJ-11 (6-pole/6-core) x 1					
Functions	Display function		Seven segment LED (two digits), charge LED, internally powered LED x 5, display LED x 3					
	Protective function		Motor overcurrent, main circuit overvoltage, motor overload, abnormal motion error detection, electrical thermal, and others	Motor overcurrent, main circuit overvoltage, motor overload, abnormal motion error detection, electrical thermal, bus voltage imbalance ^{*2} , current imbalance ^{*2} and others				
Peripherals	Accessory		I/O connector (with a case)					
	Option (separately sold)	Built-in	—					
		External	Digital operator D-CON2 ^{*1} PC communication cable K232 (RJ-11 <=> RS-232C) PC communication cable (mini USB <=> USB) ^{*2}					
Environment	Operating/storage temperature		0 - 50 °C (non-freezing)/-20 - 85 °C (non-freezing)					
	Operating/storage humidity		90 % RH or below (non-condensing)					
	Surrounding atmosphere		Interior (avoid direct sunlight), free from corrosive gas, inflammable gas, oil mist, and dust. No water, oil, and chemicals should splash.					
Compliance standard	CE marking		Low voltage directive: EN61800-5-1 EMC directive: EN61800-3					
	UL standard		UL508C					
Structure	Protection level		IP20					
	Weight		1.0kg	1.3kg	1.0kg	1.3kg	2.0kg	

*1 For D-CON2, contact THK.

*2 A USB cable should be provided by customers.

Peripherals Configuration

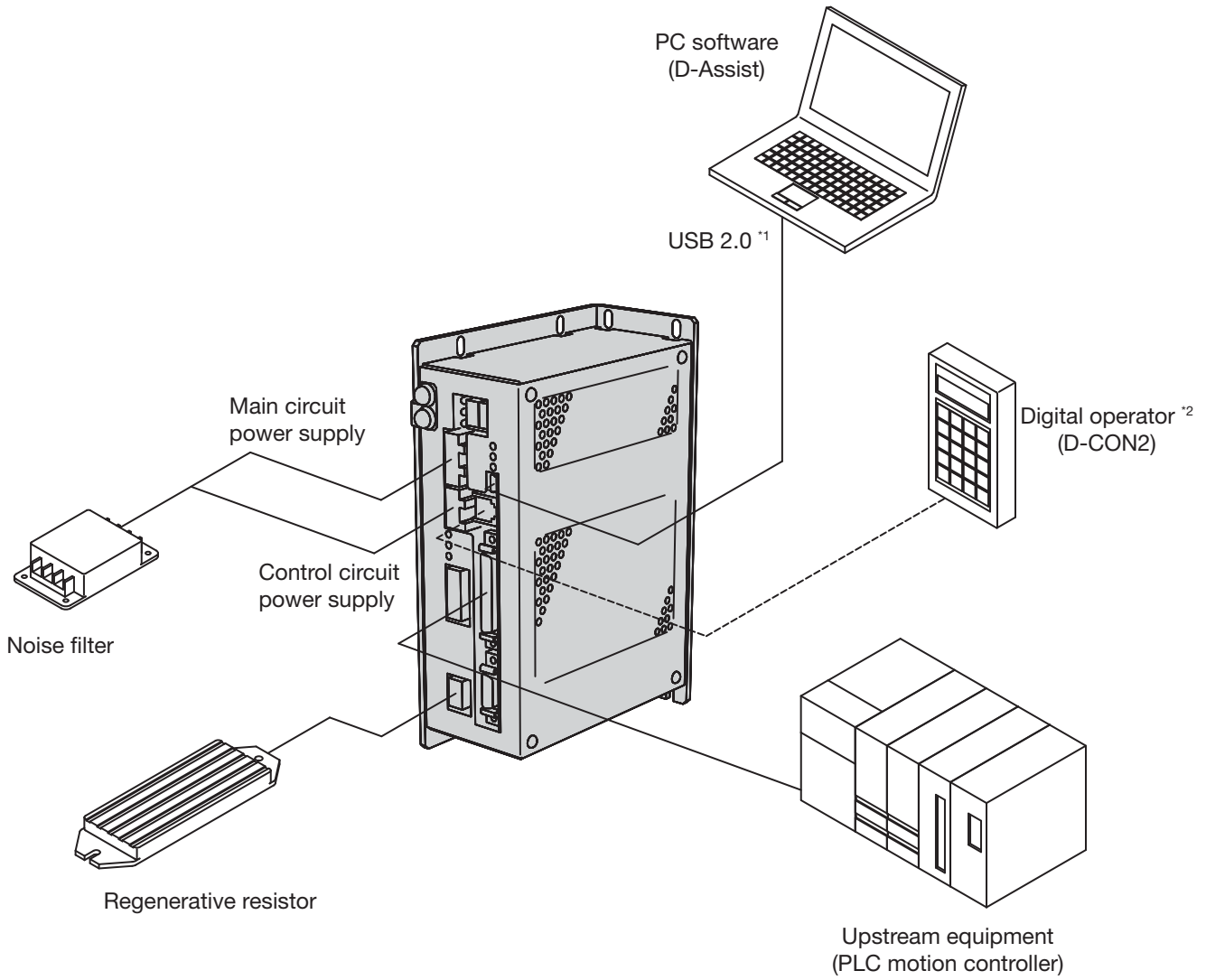

*1 To connect these peripherals to the personal computer, the USB2.0 or the RS-232C should be used.

*2 When using the digital operator (D-CON2), contact THK.

I/O List

I/O	CN7 Pin number	Signal name	Function descriptions	
Input	3	GND	I/O external power supply (24 VDC)	
	4	+24V		
	5	SG	Signal ground (for positional directive, analog monitor)	
	7	PULSE	Sign + pulse column, positional directive (pulse column input) The CW + CCW method and the two-phase pulse column method with a phase difference can be also selected with parameter settings.	
	8	/PULSE		
	9	DIR	Sign + pulse column method, positional directive (sign input) The CW + CCW method and the two-phase pulse column method with a phase difference can be also selected with parameter settings.	
	10	/DIR		
	11	S-ON	Servo on	
	12	GND		
	13	P-OT	Forward run prohibited	
	14	GND		
	15	N-OT	Reverse run prohibited	
	16	GND		
	17	UI1	Auxiliary input The location deviation clear function can be allocated with parameter settings.	
	18	GND		
	19	INH	Positional reference pulse inhibit	
	20	GND		
	21	DBK	Dynamic brake function cancellation	
	22	GND		
	23	ALM-RST	Alarm reset	
	24	GND		
	25	—	Unusable	
	26	—		
	Output	27	S-RDY	Servo ready
		28	GND	
		29	INPOS	Positioning completion
30		GND		
31		ALO0	Alarm code (3-bit output)	
32		GND		
33		ALO1		
34		GND		
35		ALO2		
36		GND	Alarm	
37		ALM		
38		GND	Unusable	
39		—		
40		—		
41		—		
42		—		
43		PAO	Positional signal (phase A)	
44		/PAO		
45		PBO	Positional signal (phase B)	
46		/PBO		
47		PZO	Positional signal (phase Z)	
48		/PZO		
49		AN0-MON	Analog monitor (CN0)	
50		AN1-MON	Analog monitor (CN1)	

Model Configuration

Model number	Capacity	Input power	Actuator	Resolution	Magnetic pole sensor
TDP	075CU	200AC	GA20MU	1U	N
①	②	③	④	⑤	⑥

Driver elements

Actuator elements

① Model number	TDP
② Capacity	010CU : 100W 020CU : 200W 045CU : 450W 075CU : 750W 100CU : 1kW 150CU : 1.5kW 300CU : 3kW
③ Input power	100AC : Single-phase 100 VAC 200AC : Single/three-phase 200 VAC * The 1-kW, 1.5-kW, and 3-kW capacity specifications support the input power of three-phase 200 VAC only.

④ Actuator	Example) G10M : GLM10 M type GA20MU : GLM20AP M type GA20LU : GLM20AP L type * For details, see the model number list (Chapter 8 128). G15S : GLM15 S type K46S : KLM46 S type R11H : RDM-mini H type
------------	--

⑤ Resolution	10U : 10.0μm 5U : 5.0μm 1U : 1.0μm 500N : 0.5μm 100N : 0.1μm	<table border="1"> <thead> <tr> <th rowspan="2">Actuator</th> <th colspan="5">Resolution</th> </tr> <tr> <th>10U (10.0μm)</th> <th>5U (5.0μm)</th> <th>1U (1.0μm)</th> <th>500N (0.5μm)</th> <th>100N (0.1μm)</th> </tr> </thead> <tbody> <tr> <td>GLM10</td> <td></td> <td>●</td> <td>●</td> <td>●</td> <td>●</td> </tr> <tr> <td>GLM15</td> <td>●</td> <td>●</td> <td>●</td> <td>●</td> <td>●</td> </tr> <tr> <td>GLM20AP</td> <td>●</td> <td>●</td> <td>●</td> <td>●</td> <td>●</td> </tr> <tr> <td>GLM25</td> <td>●</td> <td>●</td> <td>●</td> <td>●</td> <td>●</td> </tr> <tr> <td>KLM46</td> <td></td> <td></td> <td>●</td> <td>●</td> <td>●</td> </tr> <tr> <td>RDM-mini</td> <td></td> <td>●</td> <td>●</td> <td>●</td> <td></td> </tr> </tbody> </table>	Actuator	Resolution					10U (10.0μm)	5U (5.0μm)	1U (1.0μm)	500N (0.5μm)	100N (0.1μm)	GLM10		●	●	●	●	GLM15	●	●	●	●	●	GLM20AP	●	●	●	●	●	GLM25	●	●	●	●	●	KLM46			●	●	●	RDM-mini		●	●	●	
Actuator	Resolution																																																
	10U (10.0μm)	5U (5.0μm)	1U (1.0μm)	500N (0.5μm)	100N (0.1μm)																																												
GLM10		●	●	●	●																																												
GLM15	●	●	●	●	●																																												
GLM20AP	●	●	●	●	●																																												
GLM25	●	●	●	●	●																																												
KLM46			●	●	●																																												
RDM-mini		●	●	●																																													

⑥ Magnetic pole sensor	J : With magnetic pole sensor N : Without magnetic pole sensor * For KLM46 and RDM-mini, only N (without magnetic pole sensor) is used.
------------------------	---

Type List

⑤:Resolution
⑥:Magnetic pole sensor

Capacity	Input power	Actuator	Driver model number
100W	Single-phase 100 VAC	GLM10 S type	TDP-010CU-100AC-G10S-⑤-⑥
		GLM10 M type	TDP-010CU-100AC-G10M-⑤-⑥
		GLM15 S type	TDP-010CU-100AC-G15S-⑤-⑥
	Single/three-phase 200 VAC	GLM10 S type	TDP-010CU-200AC-G10S-⑤-⑥
		GLM10 M type	TDP-010CU-200AC-G10M-⑤-⑥
		GLM15 S type	TDP-010CU-200AC-G15S-⑤-⑥
		KLM46 S type	TDP-010CU-200AC-K46S-⑤-⑥
200W	Single-phase 100 VAC	GLM15 M type	TDP-020CU-100AC-G15M-⑤-⑥
	Single/three-phase 200 VAC	GLM15 M type	TDP-020CU-200AC-G15M-⑤-⑥
		KLM46 M type	TDP-020CU-200AC-K46M-⑤-⑥
450W	Single-phase 100 VAC	GLM20AP S type	TDP-045CU-100AC-GA20SU-⑤-⑥
		RDM-mini S type	TDP-045CU-100AC-R11S-⑤-⑥
		RDM-mini M type	TDP-045CU-100AC-R11M-⑤-⑥
		RDM-mini L type	TDP-045CU-100AC-R11L-⑤-⑥
		RDM-mini H type	TDP-045CU-100AC-R11H-⑤-⑥
	Single/three-phase 200 VAC	GLM20AP S type	TDP-045CU-200AC-GA20SU-⑤-⑥
	750W	Single-phase 100 VAC	GLM20AP M type
Single/three-phase 200 VAC		GLM20AP M type	TDP-075CU-200AC-GA20MU-⑤-⑥
1kW	Three-phase 200 VAC	GLM20AP L type	TDP-100CU-200AC-GA20LU-⑤-⑥
1.5kW	Three-phase 200 VAC	GLM25 S type	TDP-150CU-200AC-G25S-⑤-⑥
3kW	Three-phase 200 VAC	GLM25 M type	TDP-300CU-200AC-G25M-⑤-⑥

Dimension Diagram

TDP-010CU, TDP-020CU, TDP-045CU

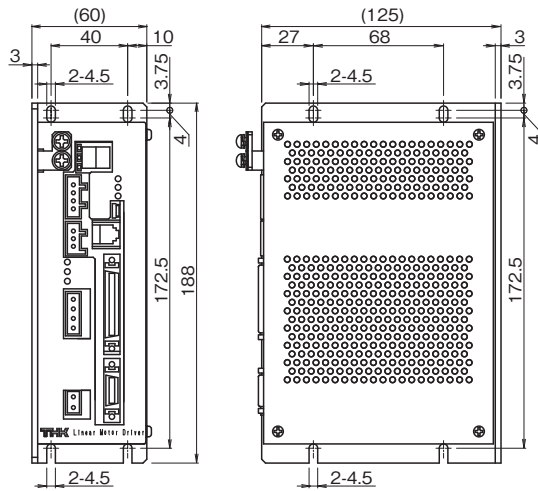

TDP-075CU

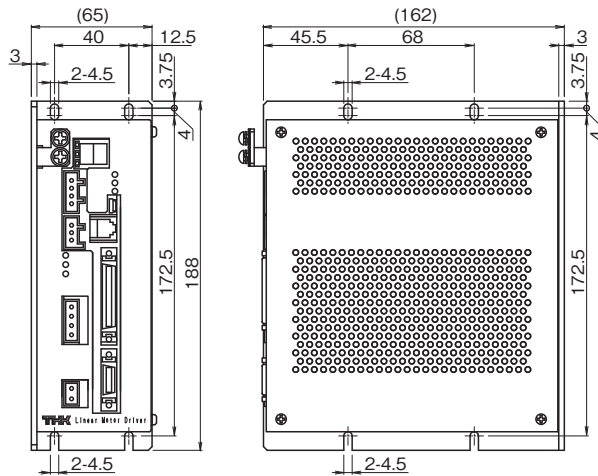

TDP-100CU

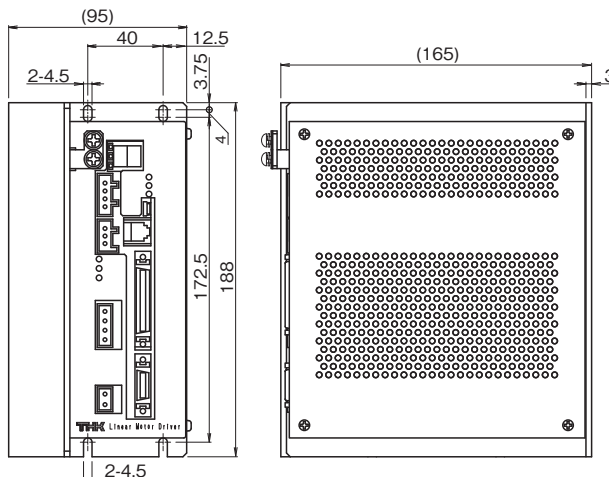

Interpolator Outer Dimensions (Case of Specifications of Magnetic Linear Encoder (Magnescale Co., Ltd.))

MJ100

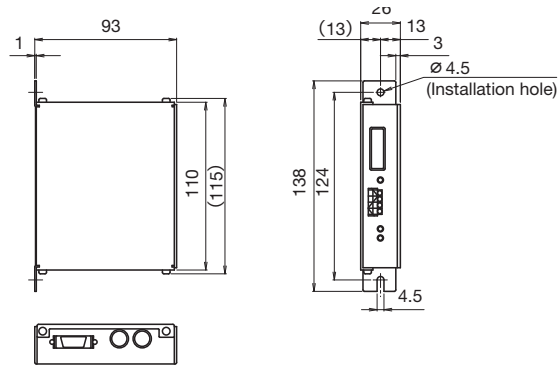

Note) Provided with the magnetic linear encoder made by Magnescale Co., Ltd.

Cable Specifications

KDK-**-CU: Motor cable

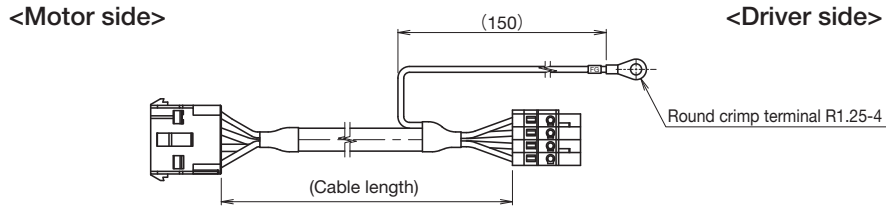

Plug housing: 172167-1 (Tyco Electronics Japan G.K.)
Socket: 171639-1 (Tyco Electronics Japan G.K.)

Plug: 231-104 (WAGO Company of Japan, Ltd.)

KET-**-CU: Optical linear encoder cable

Note) Used for the optical linear encoder made by RENISHAW Inc.

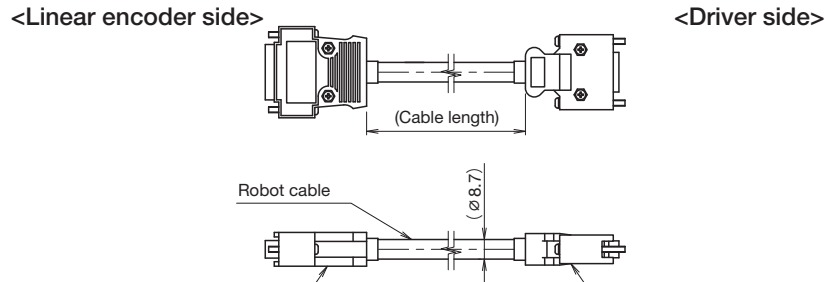

Hood: XM2S-1513 (OMRON Corporation)
Socket: XM2D-1501 (OMRON Corporation)

Non-shield shell kit: 10320-52A0-008 (Sumitomo 3M Limited)
Plug: 10120-3000PE (Sumitomo 3M Limited)

KJET-**-CU: Optical linear encoder/magnetic pole sensor cable

Note) Used for the optical linear encoder made by RENISHAW Inc.

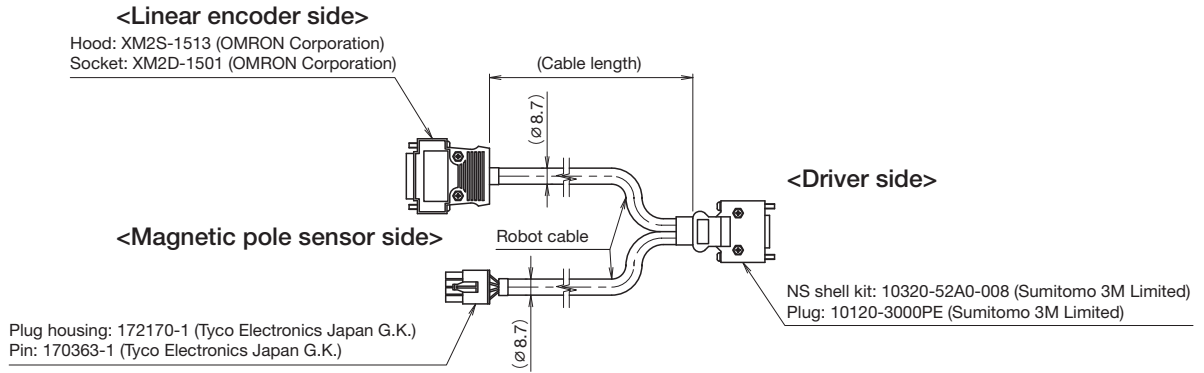

KEK-**-CU: Optical linear encoder cable

Note) Used for the optical linear encoder made by HEIDENHAIN Inc.

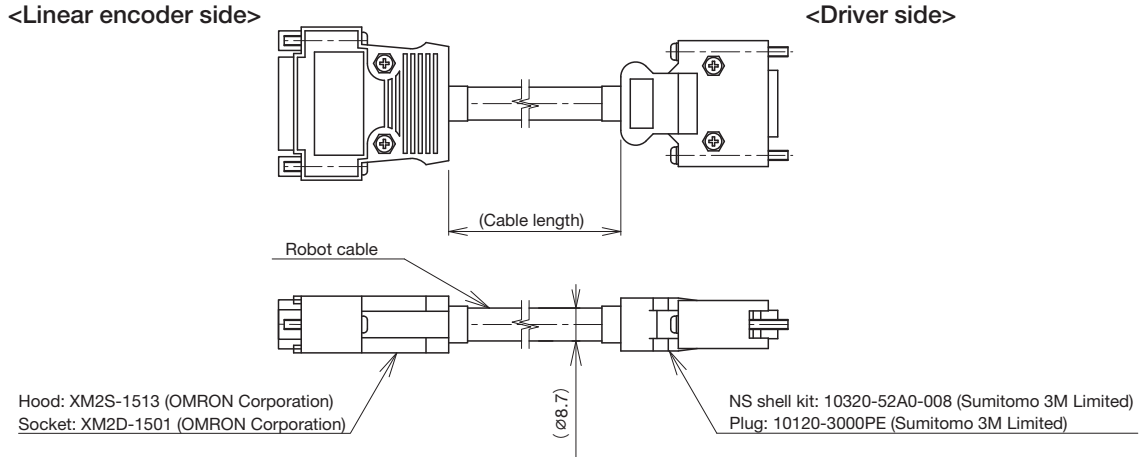

KHET-**-CU: Optical linear encoder/magnetic pole sensor cable

Note) Used for the optical linear encoder made by HEIDENHAIN Inc.

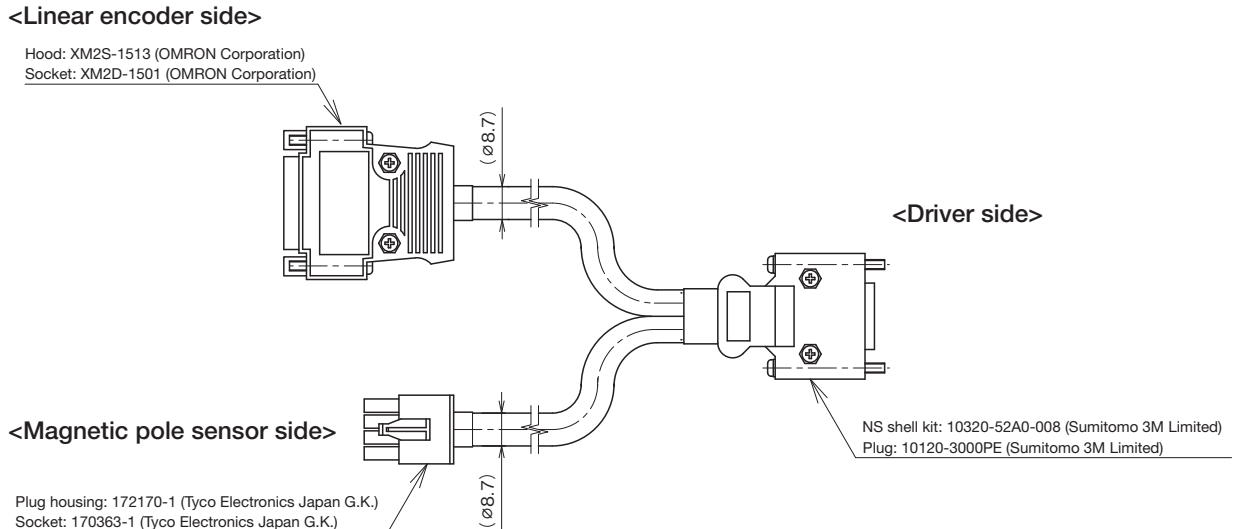

CK-**-CU: Magnetic linear encoder cable

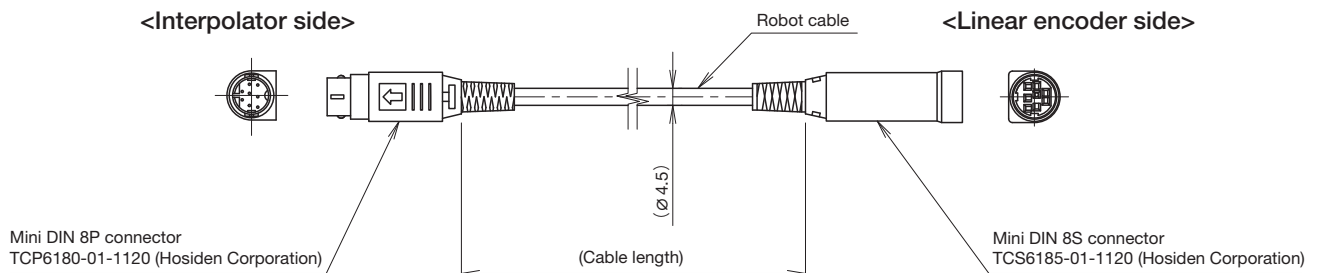

KSET.01.CU: Connection cable between interpolator and driver

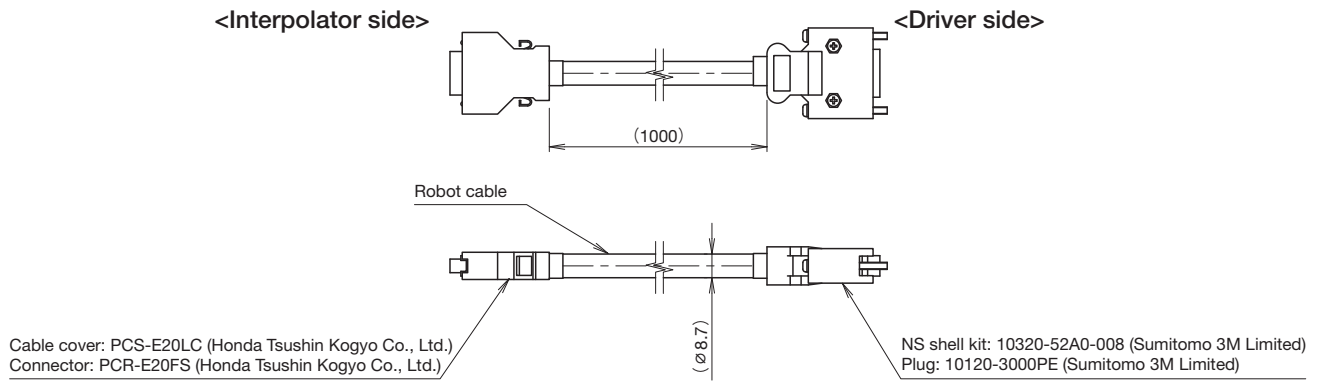

KSJT--CU: Connection cable between interpolator/magnetic pole sensor and driver**

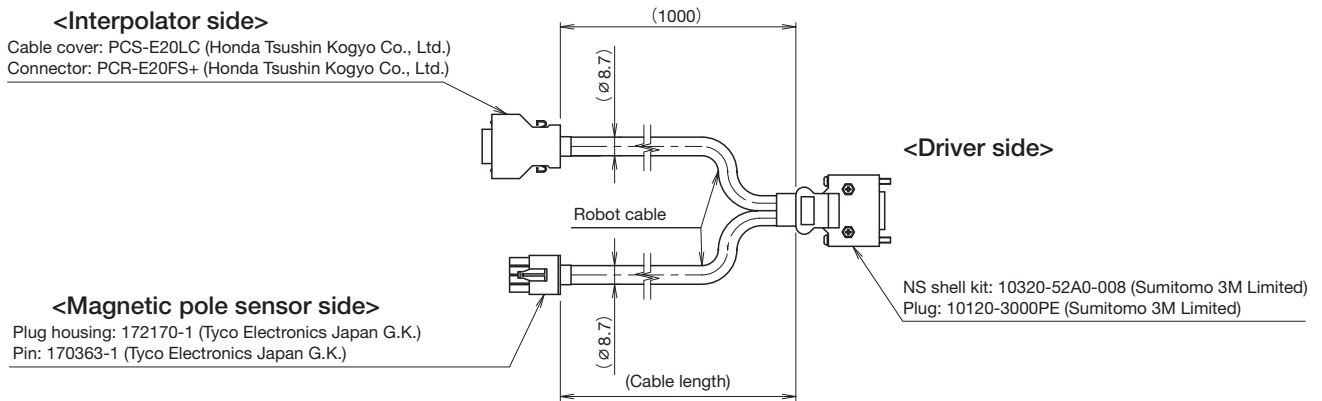

CE09-: Origin detector cable**

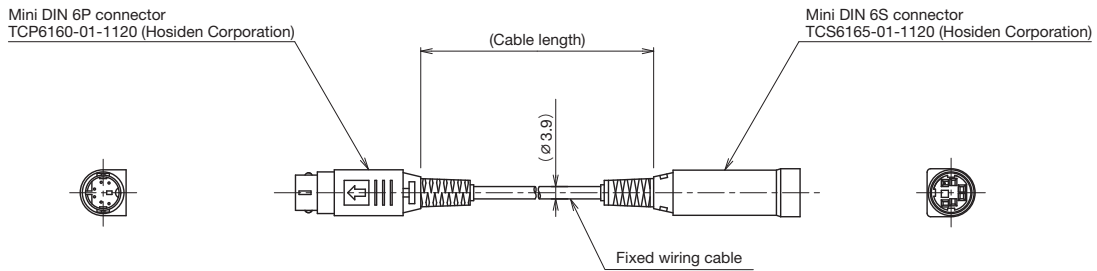

K232-01: PC communication cable RS-232C

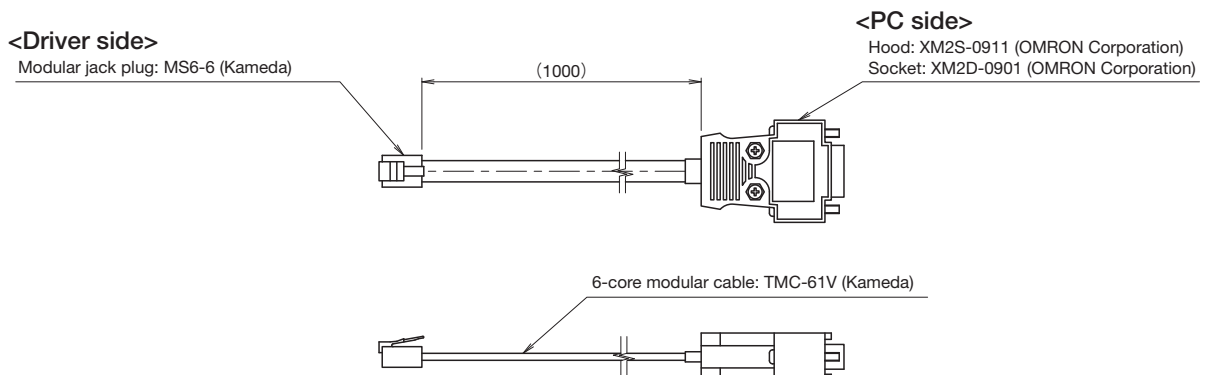

GLM20AP Selection Method

Select the linear motor following the procedure below.

* If you provide the usage conditions, THK can select a recommended model number.
Please contact THK.

1. Evaluate the maximum thrust ratio

Make sure that the maximum thrust of the motor exceeds the required thrust for operations.
It is recommended to use with **80% or less** of the maximum thrust by load fluctuations into account.

2. Evaluate the RMS thrust ratio

Make sure that the rated continuous thrust of the motor exceeds the required RMS thrust.
It is recommended to use with **70% or less** of the rated continuous thrust by taking load fluctuations into account.

* It is recommended to use with 60% or less of the the rated continuous thrust when using the actuator in a ceiling mount.
Please contact THK for details.

3. Confirm the specifications of the selected model number

Check the detailed specifications of the model number selected using the above process, to ensure that external dimensions, stroke, maximum speed, resolution and positioning repeatability all satisfy the requirement.

4. Selection of regenerative resistor

A regenerative resistor may be required depending on the operating conditions.
Check the "GLM20AP Instruction Manual" and Evaluation of regenerative resistor (→ P.35) for the selection method.

Calculation conditions

m_1	Payload	[kg]
m_2	Slider mass	[kg]
V	Motion speed	[m/s]
g	Gravitational acceleration (9.807m/s ²)	
μ	Friction coefficient	
α	Acceleration	[m/s ²]
L	Stroke	[m]
P	Motor attraction force	[N]
f	Sliding resistance of LM block	[N]
n	No. of LM blocks being used	
T	1 cycle time	[s]
t_1	Acceleration time	[s]
t_2	Constant speed time	[s]
t_3	Deceleration time	[s]
t_4	Stop time	[s]

Data for selection

Motor type	S type	M type	L type
Slider mass: m_2 [kg]	5.3 (5.1)	9.1 (8.9)	12.9 (12.7)
Motor attraction force: P [N]	1232	2547	3728
No. of LM blocks being used: n [pcs]	4	6	8
Sliding resistance of LM block: f [N]	3.7		
Friction coefficient: μ	0.01		
Maximum load capacity [kg] *1	46.1	86.1	134.6
Estimated load capacity [kg] *2	7.7	15.0	24.5

Note: The values in () are for the specifications without the magnetic pole sensor.

*1 Speed or acceleration/deceleration may be reduced by the payload mass. See "GLM20AP Selection Method" on Pages 30 to 34.

The maximum load capacity is the mass that can be driven with the acceleration of approx. 0.5G.

*2 The estimated load capacity is the mass that can be driven with the acceleration of approx. 2G, with the maximum speed of 1.0 m/s, and at a duty factor of 50% of a constant stroke.

However, operable mass may vary as it may be affected by thrust-speed characteristics depending on speed.

Table 1. Permissible driver regenerative energy

Driver model no.	Permissible regenerative energy E_2 [J]	Minimum permissible resistance [Ω]	Regenerative power [W]			
			RH120 100 Ω	RH150 100 Ω	RH220 100 Ω	RH300C 100 Ω
				RF180 100 Ω	RF240 100 Ω	
TD-045CU-200AC-GA20SU	4.5	100	70	90	120	200
TD-075CU-200AC-GA20MU	13.1	100	70	90	120	200
TD-100CU-200AC-GA20LU	19.7	100	70	90	120	200

Table 2. External regenerative resistor and reference model for reference

Name	Type	Specifications	Manufacturer
Regenerative resistor	RH*** 100 Ω *	Without thermostat	Iwaki Musen Kenkyusho
	RH*** 100 Ω * -***B	With thermostat (external)	
	RF*** 100 Ω * -***B	With thermostat (internal)	
Female plug: 2-pole Pin pitch: 5.08mm	231-302/026-000		WAGO

Note: * under the Type column of the regenerative resistor indicates, from the left toward the right, the power, permissible resistance, and thermostat temperature, respectively. For details, refer to the manufacturer's catalog.

Evaluating the maximum thrust ratio

The required maximum thrust F_{\max} is the largest value out of the values calculated by the following three formulas:

Load force: F [N]
$F = \mu \times m_1 \times g$
Thrust during acceleration: F_a [N]
$F_a = (m_1 + m_2) \times \alpha + F$
Thrust during deceleration: F_{d1} [N]
$F_{d1} = (m_1 + m_2) \times \alpha - F$

Required maximum thrust F_{\max} : Maximum value of F , F_a and F_{d1} above

Find the maximum thrust F_{peak} of the actuator at the motion speed from the thrust-speed characteristics chart in product specifications (\rightarrow P.6).

Maximum thrust ratio (%): $\frac{F_{\max}}{F_{\text{peak}}} \times 100$ 80% or less is recommended.

Evaluating the RMS thrust ratio

Calculate the RMS (root-mean-square) thrust from the load force, thrust during acceleration, and thrust during deceleration with respect to each duration.

RMS thrust: F_{rms} [N]
$F_{\text{rms}} = \sqrt{\frac{F_a^2 \times t_1 + F^2 \times (t_2 + t_4) + F_{d1}^2 \times t_3}{T}}$

Also, from the motion profile, average speed: V_{ave} is calculated.

Average speed: V_{ave} [m/s]
$V_{\text{ave}} = \frac{L}{T \text{ (1 cycle time)}}$

Find the rated continuous thrust F_{cont} of the motor from the thrust-speed characteristics chart in product specifications (\rightarrow P.6).

RMS thrust ratio (%): $\frac{F_{\text{rms}}}{F_{\text{cont}}} \times 100$ 70% or less is recommended.

Evaluating the regenerative resistor

Use the following formula to calculate the thrust during deceleration.

Thrust during deceleration: F_{d2} [N]

$$F_{d2} = (m_1 + m_2) \times \alpha - \{[(m_1 + m_2) \times g + P] \times \mu + f \times n\}$$

Regeneration energy: E_1 [J]

$$E_1 = F_{d2} \times t_3 \times \frac{V}{2}$$

Check the permissible regenerative energy E_2 of the driver to be used. (→ P.31 Table 1)

If $E_2 < E_1$, regeneration resistor is required.

Required capacity of regenerative resistor: W_K [W]

$$W_K = \frac{(E_1 - E_2)}{0.2 \times T}$$

Example of Selection

The examination below shows that if GLM20AP-S type can drive a payload of 10kg along the following motion profile:

Selection model	: GLM20AP-S type 200VAC specifications without magnetic pole sensor
Payload	: $m_1 = 10$ [kg]
Slider mass	: $m_2 = 5.1$ [kg]
Motion speed	: $V = 1.0$ [m/s]
Acceleration	: $\alpha = 10$ [m/s ²]
Stroke	: $L = 1.0$ [m]
Friction coefficient	: $\mu = 0.01$
Gravitational acceleration	: $g = 9.807$ [m/s ²]

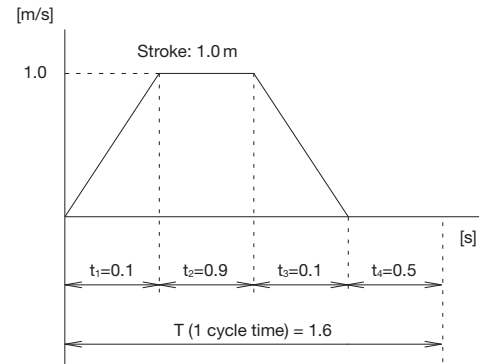

Figure: Motion profile

(1) Evaluating the required maximum thrust ratio

The required maximum thrust is the largest value out of the values calculated by the following three formulas.

$$\begin{aligned} \text{Load force} \quad : F &= \mu \times m_1 \times g \\ &= 0.01 \times 10 \times 9.807 \\ &= 1.0 \text{ [N]} \end{aligned}$$

$$\begin{aligned} \text{Thrust during acceleration} : F_a &= (m_1 + m_2) \times \alpha + F \\ &= (5.1 + 10) \times 10 + 1.0 \\ &= 152.0 \text{ [N]} \end{aligned}$$

$$\begin{aligned} \text{Thrust during deceleration} : F_{d1} &= (m_1 + m_2) \times \alpha - F \\ &= (5.1 + 10) \times 10 - 1.0 \\ &= 150.0 \text{ [N]} \end{aligned}$$

From the above calculation results:

$$\text{Required maximum thrust: } F_{\max} = F_a = 152.0 \text{ [N]}$$

Thrust-speed characteristics chart (Figure) for GLM20AP-S type shows that the thrust of the motor's maximum thrust:

$$F_{\text{peak}} \text{ (at speed = 1.0m/s)} = 325 \text{ [N]}$$

Therefore, the ratio of the required maximum thrust to the motor's maximum thrust is:

$$\frac{F_{\max}}{F_{\text{peak}}} \times 100 = \frac{152}{325} \times 100 = \underline{47[\%]} (\leq 80\%)$$

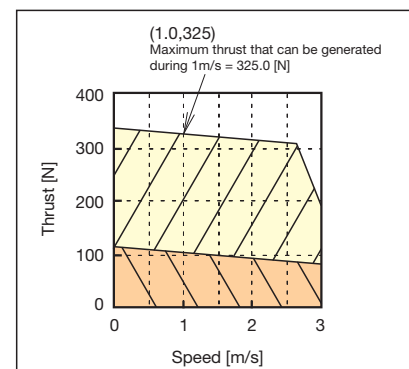

Motor type : S type
Driver : TD-045CU-200AC-GA20SU

Figure: Thrust-speed characteristics chart

(2) Evaluating the RMS thrust ratio

Calculate the RMS (root-mean-square) thrust from the load force, thrust during acceleration, and thrust during deceleration with respect to each duration.

RMS thrust:

$$F_{rms} = \sqrt{\frac{F_a^2 \times t_1 + F^2 \times (t_2 + t_4) + F_{d1}^2 \times t_3}{T}}$$

$$= \sqrt{\frac{152.0^2 \times 0.1 + 1.0^2 \times (0.9 + 0.5) + 150.0^2 \times 0.1}{1.6}}$$

$$= 53.4 \text{ [N]}$$

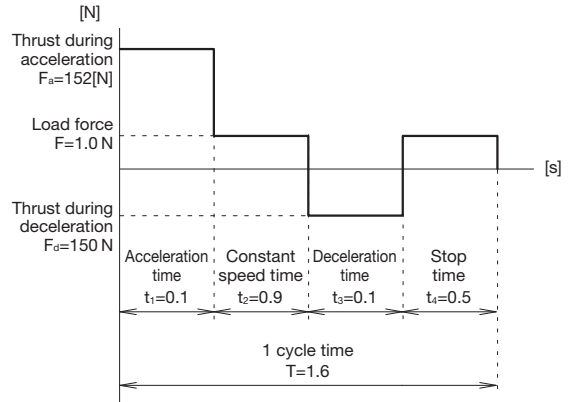

Figure: Thrust and time

Also, from the motion profile, average speed : V_{ave} is calculated:

$$V_{ave} = \frac{L}{T} = \frac{1.0}{1.6} = 0.625 \text{ [m/s]}$$

Thrust-speed characteristics chart for GLM20AP-S type shows that the thrust of the motor's rated continuous thrust:

F_{cont} (at the time of average speed 0.625m/s) = 111.5 [N]

Therefore, the RMS thrust ratio for the rated continuous thrust is:

$$\frac{F_{rms}}{F_{cont}} \times 100 = \frac{53.4}{111.5} \times 100 = 48[\%] (\leq 70\%)$$

As the result above, of the maximum thrust ratio and RMS thrust ratio, this application shall be concluded operative.

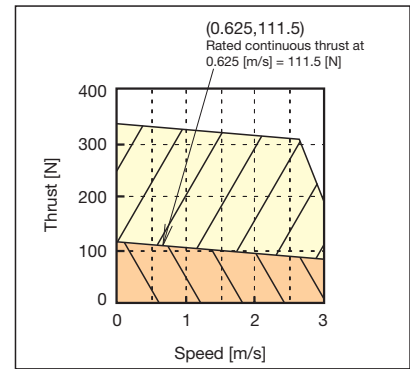

Motor type : S type
Driver : TD-045CU-200AC-GA20SU

Figure: Thrust-speed characteristics chart

(3) Evaluating the regenerative resistor

Determine whether or not a regenerative resistor is required, by comparing the value calculated from the thrust during deceleration, deceleration time and motion speed with the permissible regenerative energy of the driver.

Use the following formula to calculate the thrust during deceleration.

$$\text{Thrust during deceleration} : F_{d2} = (m_1 + m_2) \times \alpha - [(m_1 + m_2) \times g + P] \times \mu + f \times n = 122.4 \text{ [N]}$$

$$\text{Motor attraction force} : P = 1232 \text{ [N]}$$

$$\text{Sliding resistance of LM block} : f = 3.7 \text{ [N]}$$

$$\text{No. of LM blocks} : n = 4 \text{ (for GLM20AP-S)}$$

$$\text{Deceleration time} : t_3 = 0.1 \text{ [s]}$$

$$\text{Cycle time} : T = 1.6 \text{ [s]}$$

$$\text{Motion speed} : V = 1.0 \text{ [m/s]}$$

$$\text{Regenerative energy in the above case: } E_1 = F_{d2} \times t_3 \times \frac{V}{2} = 6.12 \text{ [J]}$$

From Table 1 on P.30, the permissible regeneration of the driver being used (TD-045CU-200AC-GA20SU) is:

$$E_2 = 4.5 \text{ [J]}$$

Because $E_2 < E_1$, an external regenerative resistance is required.

$$\text{The required capacity of the external regenerative resistor is: } W_K = \frac{(E_1 - E_2)}{0.2 \times T} = \underline{\underline{5.06 \text{ [W]}}}$$

The 0.2 term in the above formula is the value where the load factor for the external regenerative resistor is 20%.

Because the required capacity of the external regenerative resistor is 5.06 W, select a recommended regenerative resistor model number with the capacity of 5.06W or more.

* Minimum permissible resistance of TD-045CU-200AC-GA20SU = 100 [Ω]

Therefore, select the RH120 100 Ω (70W) [Iwaki Musen Kenkyusho].

Note 1: Check with the manufacturer for detailed specifications of the external regenerative resistor, including load characteristics and thermostat specifications.

Note 2: If an external regenerative resistor is required, the customer is to provide the connector (\rightarrow P.31 Table 2).

Application Example

Laser marking

Machining, assembly

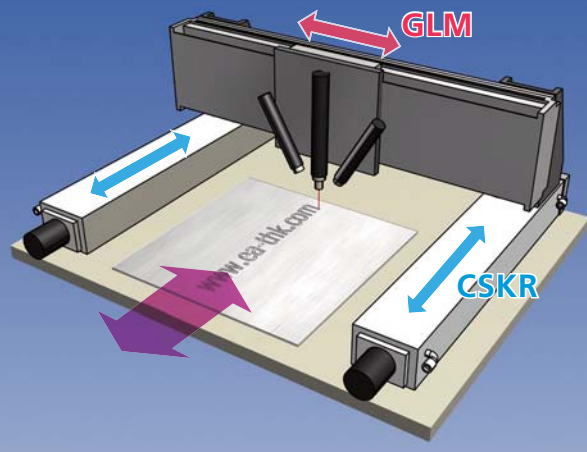

Model No.

CSKR and GLM are used for the section that moves the laser. By using CSKR, clean series, and GLM, a series that drives the load without physical contact and generates little dust, application in a clean room has been made possible.

CSKR GLM

Printer

Other

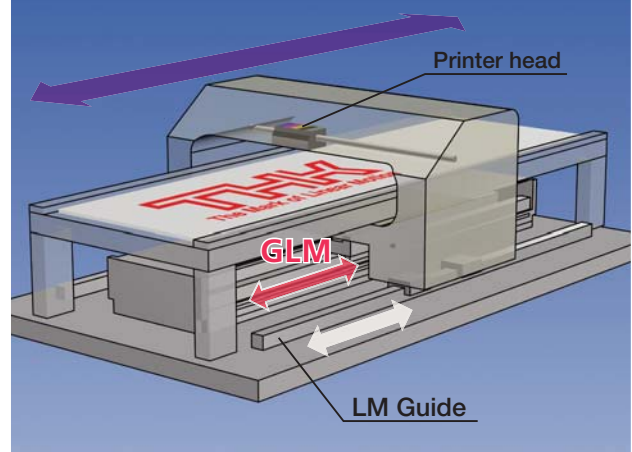

Model No.

GLM is used for the transfer section of the head. By using GLM that boasts of a high precision and a high resolution, high-definition printing is possible.

GLM LM Guide

Liquid crystal glass inspection equipment

Inspection

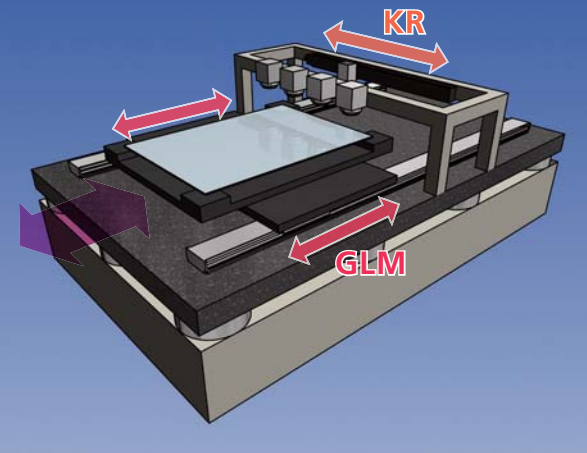

Model No.

GLM that supports long stroke and high speed is used. By using GLM, increase in work size and improvement in takt time have been made possible.

KR GLM

Dispenser

Machining, assembly

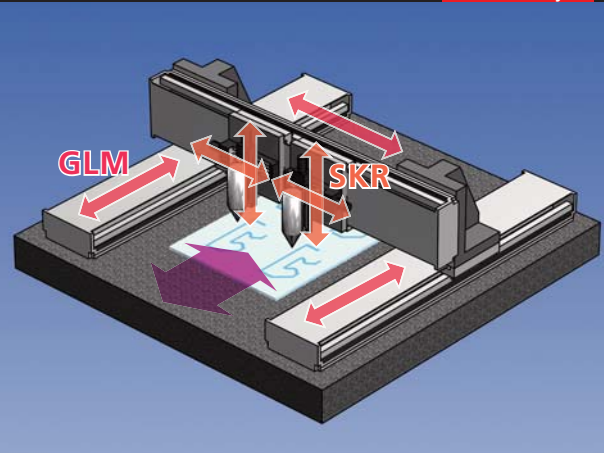

Model No.

SKR and GLM are used for the dispenser section. The use of a linear motor delivers high-speed and smooth operation, improving the dispensing accuracy.

SKR GLM

Nut runner

Machining, assembly

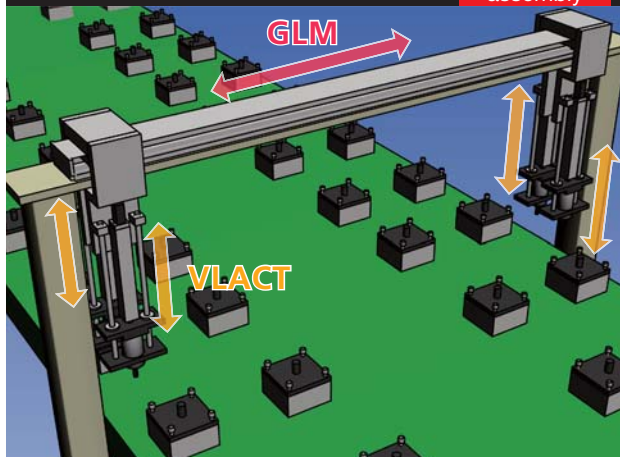

Model No.

VLACT is used for the elevating section of a screw tightening machine and GLM is used for the transfer section. By performing independent control operations with a multiple-slider model in the linear motor series, productivity can be improved.

GLM VLACT

Glass substrate inspection equipment

Inspection

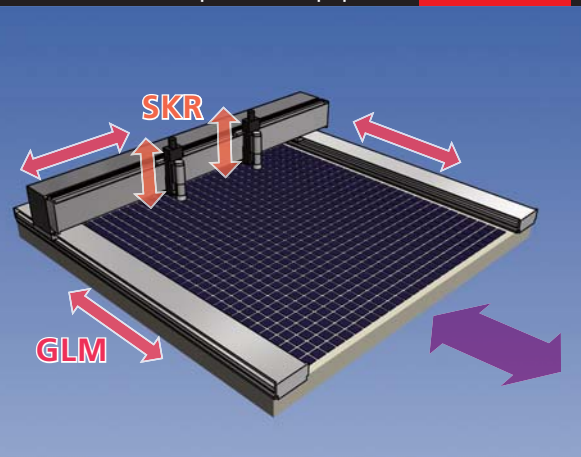

Model No.

GLM and SKR are used for the camera transfer section of the inspection equipment. By using the portal structure, large-sized work can be supported.

GLM SKR

| Maximum thrust |

Indicates the largest value of the force that the slider can generate instantaneously.

| Magnetic pole sensor |

The sensor that identifies N and S poles of the magnet. This is used to detect the relative position between the coil and polarity of the permanent magnet.

| Optical linear encoder |

A position detector that detects the position of the slider by using light (laser light). This is used for applications that require high precision and high resolution.

| Magnetic linear encoder |

A position detector that detects the position of the slider by using magnetism. This possesses superb environmental resistance compared to the optical type.

| CE compliance |



Statutory safety logo for the products sold in the EU region. For the unit products such as drivers, etc., obtaining the CE compliance approval became fully compulsory from January 1996 by the EMC directive and low voltage directive.

(1) EMC Directive

- Immunity test: Capacity to withstand noise from outside
- Emission test: Capacity to reduce the release of noise to outside

(2) Low Voltage Directive

- Requirement of electric safety for the electric products that are operated by the power source of 50 to 1000VAC and 75 to 1500VDC.

| RoHS Directive |

This is a hazardous substances control act enforced by EU on July 1, 2006, prohibiting electric and electronic equipment to contain the specified hazardous substances. If the products contain the hazardous substances that are controlled by this directive, they cannot be sold within the EU region.

| UL Standard |



UL stands for Underwriters Laboratories Inc., a nonprofit organization in the United States. The UL standard created by UL has garnered public trust as the highest authority for safety standards, and UL Marking is used by many state and local governments in the US.

UL has been approved as the certification and testing agency in Canada by the Canadian Standards Association, and is recognized throughout all states in Canada.

If the products are evaluated in accordance with the safety standards of both America and Canada, and prove that they conform to the standards, they can bear UL Marking, c-UL Marking, or a combination of these.

| Rated continuous thrust |

Indicates the force that the slider can continuously generate.

| Maximum load capacity |

Indicates the maximum mass that can be transferred by loading onto the actuator.

* THK defines the maximum load capacity as the mass that can be transferred with approx. 0.5G acceleration. For actual selection, see Selection Method (P.27 to 33) in this catalog and please contact THK.

| Resolution |

Minimum travel distance that can be set.

Note: This does not guarantee the positioning accuracy.

| Positioning repeatability |

Position to a given point from the same direction seven times, measure the stopping points and then calculate the value of half the maximum difference of the reading. Perform this measurement at the center and at both ends of the travel distance; the largest value becomes the measurement value, and the positioning repeatability is expressed by placing the symbol "±" next to the value of half the maximum difference.

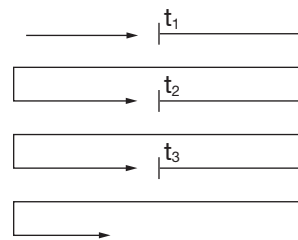

= 1/2 of the maximum difference between t_1 t_2 ... t_7

| THK green procurement |

THK Group, through the development of its business activities as well as the social life of each employee, acknowledges that we are deeply related to the global environment, and thus would like to effectively tackle reducing environmental impact. When procuring raw materials and parts used in the production of the products, or those indirect materials and tools used in the production processes, THK Group implements the measures to consider reducing their impact on the environment.

Precautions on Use

● Environment

- The wrong environment can cause failure for the actuator and driver. The best places to use the device are as follows:
- For actuators, an environment with a room and ambient temperature from 0 to 40 °C and humidity of no more than 80% RH that will not expose the product to freezing or condensation.
 - For drivers, an environment with a room and ambient temperature from 0 to 50 °C and humidity of no more than 90% RH that will not expose the product to freezing or condensation.
 - A place free from corrosive gas or flammable gas.
 - Places where none of the following are flying around: iron particles, or any other conductive particles, dust, oil mist, cutting fluid, water, salt, organic solvents.
 - Places that are not exposed to direct sunlight or radiant heat.
 - Places where no strong electric fields or strong magnetic fields occur.
 - Places where vibration or impact are not transmitted to the unit.
 - Places that are easy to inspect and clean.

● Safety Precautions

- This product consists mostly of heavy items (20 kg or more). When moving heavy items, use 2 or more people or moving equipment. Otherwise, injury or damage may occur.
- When transporting and installing this unit, mount the supplied eye nut to the base and attach the slider fixing screw. Always remove the eye nut and slider fixing screw when operating the actuator.
- Do not drop or knock this product. Doing so may cause injury or damage the unit.
- Unnecessarily disassembling this product may allow foreign objects to enter and reduce functionality. Also, there is a risk of electric shock from the driver.
- The PL seal is attached to the magnetic plate, the end plate, the slider and the connector box of the actuator unit.
- The magnetic plate (stator) is a very powerful magnet. Keep magnetic bodies (particularly metals) away from the magnet plate. There is a risk of getting the finger(s) jammed between the metal body and the magnet due to the attractive force of the magnet. Also, persons using cardiac pacemakers should absolutely stay away from the magnet.
- Never touch the moving section of the actuator when it is energized. Also, when the product is in motion, or in a state of readiness for motion, do not enter the movement zone of the actuator.
- When carrying out installation, adjustment, inspection or maintenance of the actuator unit, driver or connected associated devices, always remove all plugs from the power sockets, and use locking or safety plugs etc. so that no one but an operator can turn on the power again. Also, display a notice explaining what work is in progress in a position that is readily seen.
- If two or more people are involved in the operation, confirm the procedures such as sequences, signs, and abnormalities in advance, and appoint another person for monitoring the operation.
- Read the manual carefully, understanding the content properly, and be sure to observe all safety precautions.

● “LM GUIDE,” “Caged Ball,” and are registered trademarks of THK CO., LTD.

- The actual products may differ from the pictures and photographs in this catalog.
- Outward appearances and specifications is subject to change without notification for purposes of improvement, please inquire before using them.
- Although great care has been taken in the production of this catalog, THK will not take any responsibility for damage resulting from typographical errors or omissions.
- In exporting our products and technology, or selling them for the purpose of export, THK has a basic policy of observing laws relating to foreign exchange, trade and other laws. For export of THK products as single items, contact THK in advance.

All rights reserved

THK CO., LTD.

HEAD OFFICE 3-11-6, N ISHI-GOTAN DA, S HIN AGAWA-KU, TOKYO 141- 8503 JAPAN
INTERNATIONAL SALES DEPARTMENT PHONE:+81 -3-5434-0351 FAX:+81 -3-5434-0353
Global site : <http://www.thk.com/>

EUROPE

THK GmbH
● EUROPEAN HEADQUARTERS
Phone:+49-2102-7425-555 Fax:+49-2102-7425-556
● DUSSELDORF OFFICE
Phone:+49-2102-7425-0 Fax:+49-2102-7425-299
● STUTTGART OFFICE
Phone:+49-7150-9199-0 Fax:+49-7150-9199-888
● MUNICH OFFICE
Phone:+49-8937-0616-0 Fax:+49-8937-0616-26
● U.K. OFFICE
Phone:+44-1384-47-1550 Fax:+44-1384-47-1551
● ITALY MILAN OFFICE
Phone:+39-039-284-2079 Fax:+39-039-284-2527
● ITALY BOLOGNA OFFICE
Phone:+39-051-641-2211 Fax:+39-051-641-2230
● SWEDEN OFFICE
Phone:+46-8-445-7630 Fax:+46-8-445-7639
● AUSTRIA OFFICE
Phone:+43-7229-51400 Fax:+43-7229-51400-79
● SPAIN OFFICE
Phone:+34-93-652-5740 Fax:+34-93-652-5746
● TURKEY OFFICE
Phone:+90-216-362-4050 Fax:+90-216-569-7150
● PRAGUE OFFICE
Phone:+420-2-41025-100 Fax:+420-2-41025-199
● MOSCOW OFFICE
Phone:+7-495-649-80-47 Fax:+7-495-649-80-44
THK Europe B.V.
● EINDHOVEN OFFICE
Phone:+31-040-290-9500 Fax:+31-040-290-9599
THK France S.A.S.
Phone:+33-4-3749-1400 Fax:+33-4-3749-1401

NORTH AMERICA

THK America, Inc.
● HEADQUARTERS
Phone:+1-847-310-1111 Fax:+1-847-310-1271
● CHICAGO OFFICE
Phone:+1-847-310-1111 Fax:+1-847-310-1182
● NORTH EAST OFFICE
Phone:+1-845-369-4035 Fax:+1-845-369-4909
● ATLANTA OFFICE
Phone:+1-770-840-7990 Fax:+1-770-840-7897
● LOS ANGELES OFFICE
Phone:+1-949-955-3145 Fax:+1-949-955-3149
● SAN FRANCISCO OFFICE
Phone:+1-925-455-8948 Fax:+1-925-455-8965
● DETROIT OFFICE
Phone:+1-248-858-9330 Fax:+1-248-858-9455
● TORONTO OFFICE
Phone:+1-905-820-7800 Fax:+1-905-820-7811
SOUTH AMERICA
THK Brasil LTDA
Phone:+55-11-3767-0100 Fax:+55-11-3767-0101
CHINA
THK (CHINA) CO., LTD.
● HEADQUARTERS
Phone:+86-411-8733-7111 Fax:+86-411-8733-7000
● SHANGHAI OFFICE
Phone:+86-21-6219-3000 Fax:+86-21-6219-9890
● BEIJING OFFICE
Phone:+86-10-8441-7277 Fax:+86-10-6590-3557

CHENGDU OFFICE

Phone:+86-28-8526-8025 Fax:+86-28-8525-6357
● GUANGZHOU OFFICE
Phone:+86-20-8523-8418 Fax:+86-20-3801-0456
● SHENZHEN OFFICE
Phone:+86-755-2642-9587 Fax:+86-755-2642-9604
THK (SHANGHAI) CO., LTD.
Phone:+86-21-6275-5280 Fax:+86-21-6219-9890

TAIWAN

THK TAIWAN CO., LTD.
● TAIPEI HEAD OFFICE
Phone:+886-2-2888-3818 Fax:+886-2-2888-3819
● TAICHUNG OFFICE
Phone:+886-4-2359-1505 Fax:+886-4-2359-1506
● TAINAN OFFICE
Phone:+886-6-289-7668 Fax:+886-6-289-7669

KOREA

SEOUL REPRESENTATIVE OFFICE
Phone:+82-2-3468-4351 Fax:+82-2-3468-4353

SINGAPORE

THK LM SYSTEM Pte. Ltd.
Phone:+65-6884-5500 Fax:+65-6884-5550

THAILAND

THK LM System Pte. Ltd. Representative Office in Thailand
Phone:+660-2751-3001 Fax:+660-2751-3003

INDIA

BANGALORE REPRESENTATIVE OFFICE
Phone:+91-80-2330-1524 Fax:+91-80-2330-1524