



NEW

LM Actuator

Optimal for high speed and long stroke
Long term maintenance-free operation is actualized
Lightweight, compact structure

TY

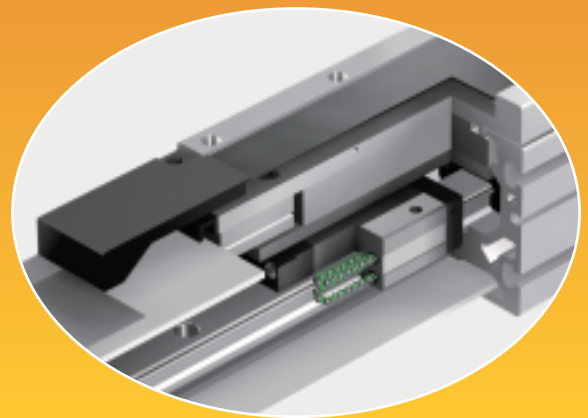
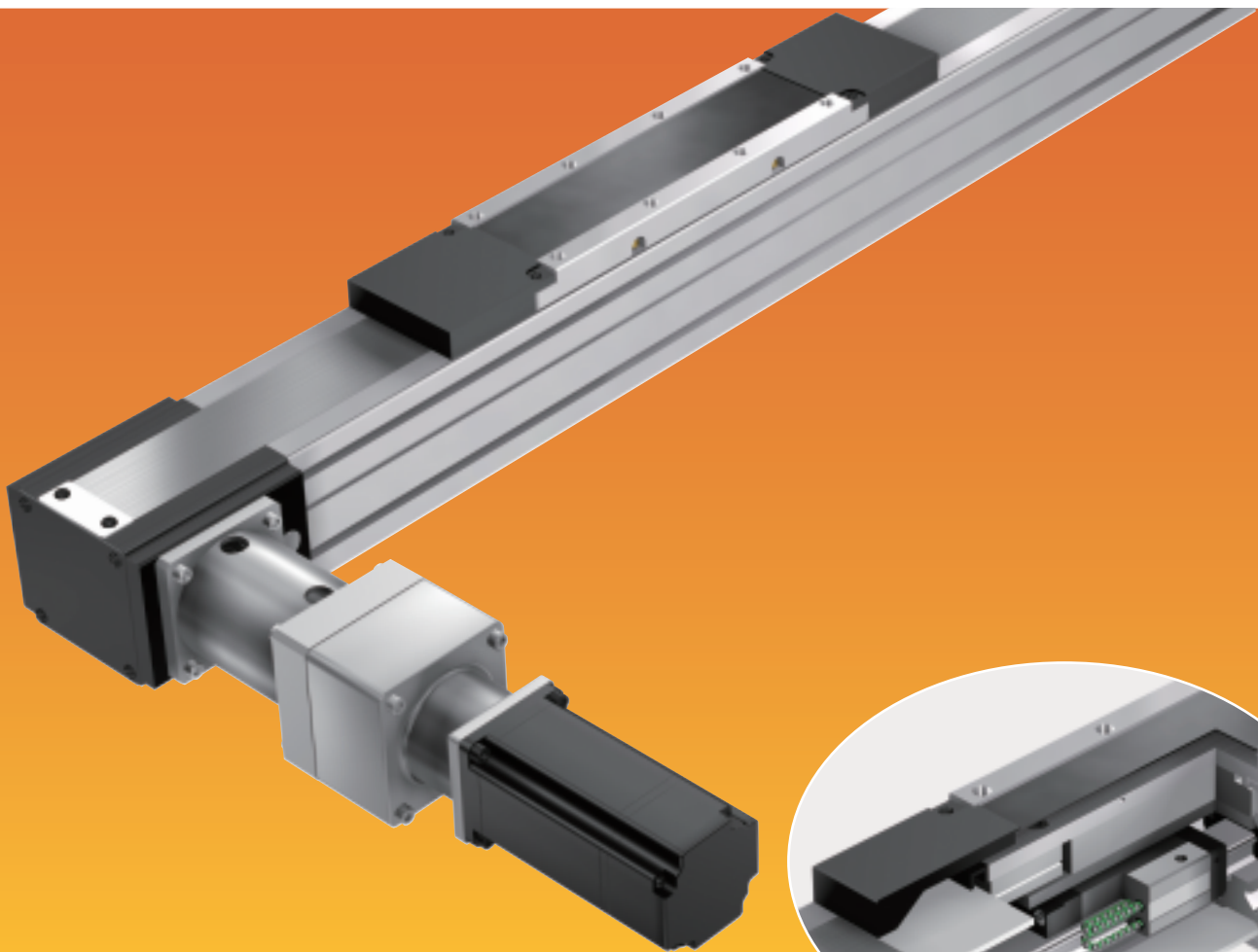

US Only

For details, visit THK at www.thk.com

*Product information is updated regularly on the THK website.

THK CO., LTD.
TOKYO, JAPAN

CATALOG No.352-3E-US

Structure of Model TY

This belt drive actuator has a caged ball LM Guide combined with a lightweight and compact aluminum base. Options such as a stainless steel cover, a motor bracket or a sensor make it useful for a variety of applications.

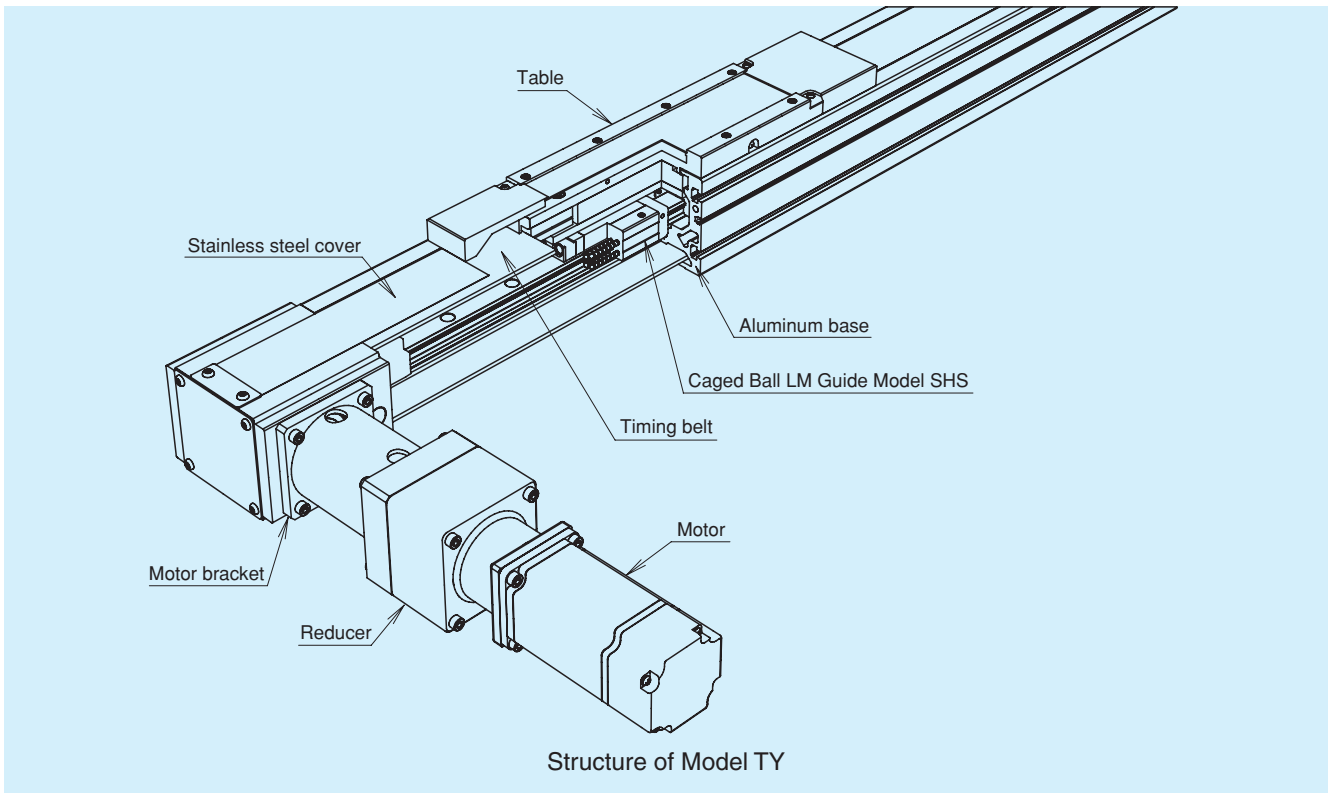

Features of Model TY

1. Optimal for long stroke high speed conveyance

A maximum stroke of 4749 mm* is possible due to the belt drive method.

A maximum travel speed of 3400 mm/s is possible when an AC servomotor (rated rotational speed 3000 min.⁻¹) with a 3:1 reducer is used.

* Stroke between the mechanical stoppers

Maximum Travel Speed

Unit: mm/s

Model no.	TY20		
Reduction ratio	1/3	1/5	1/9
Maximum travel speed	3400	2000	1100

Note 1) Please note that when the stroke is short, it may not reach the maximum travel speed.

Note 2) The maximum travel speed for actuators with a stainless steel cover is 2500 mm/s.

Table Travel Distance per Pulley Rotation

Pitch circle diameter of the pulley [mm]	Table travel distance per pulley rotation [mm]	Table travel distance [mm] per motor rotation		
		Reduction ratio: 1/3	Reduction ratio: 1/5	Reduction ratio: 1/9
65.25	205	68.3	41	22.8

Note) The timing pulley has a large pitch circle diameter, so THK recommends the use of a reducer.

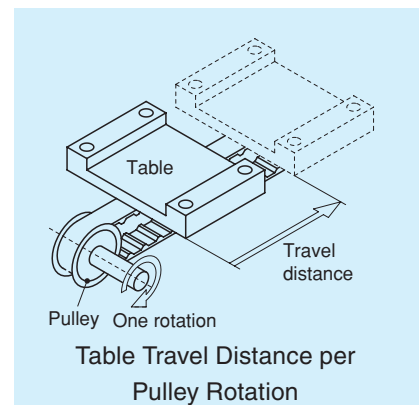

2. Long service life and long term maintenance-free operation

Built-in Caged Ball LM Guide model SHS.

Long service life and long term maintenance-free operation are possible because there is no mutual friction between the balls and grease retention is improved due to the effect of the caged ball.

QZ Lubricator is equipped as standard*.

The QZ Lubricator supplies an optimal amount of lubricant to the raceway of the LM rail, substantially extending maintenance intervals.

* For Model TY, the QZ Lubricator is equipped on a single side only for each LM block.

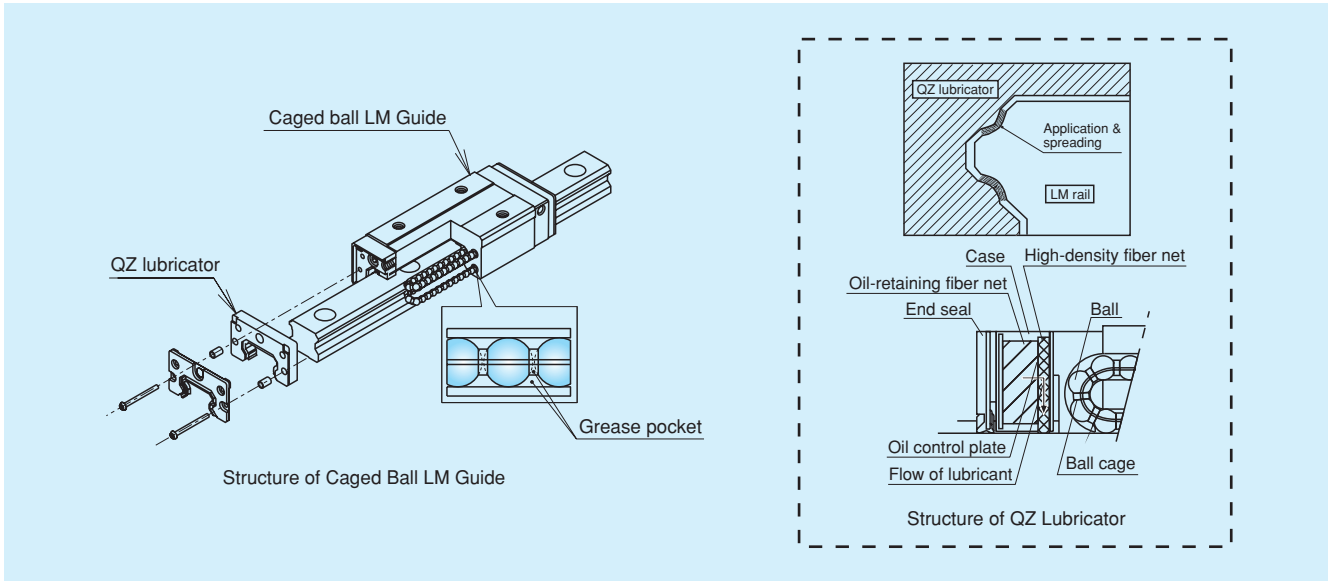

3. Quality dustproof cover optional*

A tightly sealing stainless steel cover prevents foreign matter from entering the actuator.

* Please note that, with a stainless steel cover, maximum base length and maximum travel speed will be restricted.
(Maximum base length: 3540 mm; maximum travel speed: 2500 mm/s)

4. Lightweight, compact structure

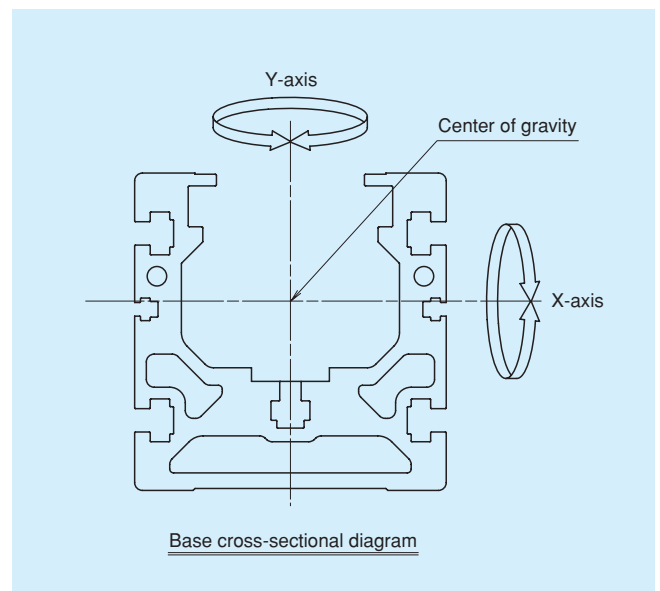
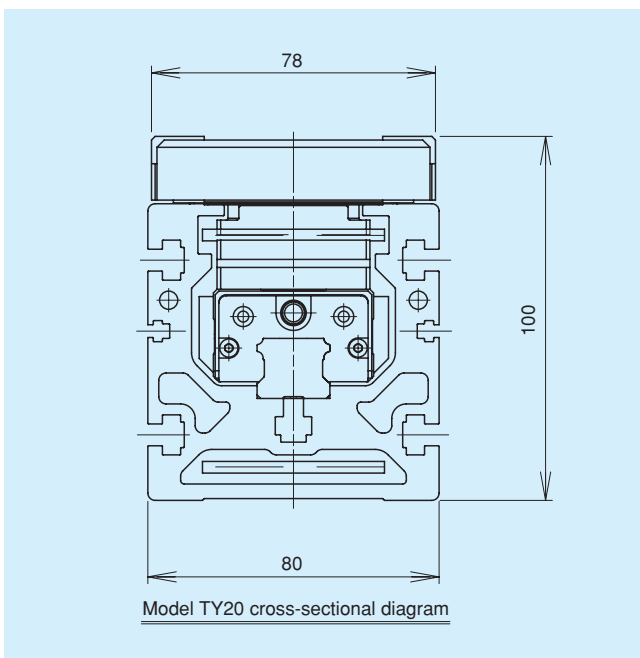

Base geometrical moment of inertia	I_x [mm ⁴]	1.49×10^6
	I_y [mm ⁴]	1.94×10^6
Mass [kg/m]		6.65

Specifications

Model no.		TY20	
Drive method		Timing belt drive	
Pitch circle diameter of the pulley [mm]		65.25	
Positioning repeatability ^{Note 1)} [mm]		±0.1	
Mechanical Stroke ^{Note 2)} [mm]		549 to 4749 (specifications without a stainless steel cover)	
Model no. for LM Guide use		SHS20V (Two blocks)	
LM Guide unit	Basic dynamic load rating C [N]	22300	
	Basic static load rating C ₀ [N]	38400	
Static Permissible Load ^{Note 3)} [N]	Axial direction	1100	
Static Permissible Moment ^{Note 4)} [N-m]	M _A	2000	
	M _B	600	
	M _C	500	
Maximum load capacity guideline ^{Note 5)} [kg] (horizontal mount)	Reduction ratio 1/3	Motor output 750 W	15
	Reduction ratio 1/5	Motor output 750 W	30
	Reduction ratio 1/9	Motor output 400 W	55

Note 1) Positioning repeatability is standardized at an ambient temperature of 20°C.

Note 2) Effective stroke is less than mechanical stroke for stainless steel cover option.

Please refer to the dimensions tables for details (page 6).

Note 3) For the axial direction, it is determined by the torsion strength of pulley shaft.

Note 4) Static permissible moment is the maximum value of the moment that can load on each direction.

Note 5) Maximum load capacity guideline is the load during rated speed of the motor at the acceleration/deceleration of 0.5G. Also, the travel life of the LM Guide unit must be evaluated separately. For details, see the appendix on page 13.

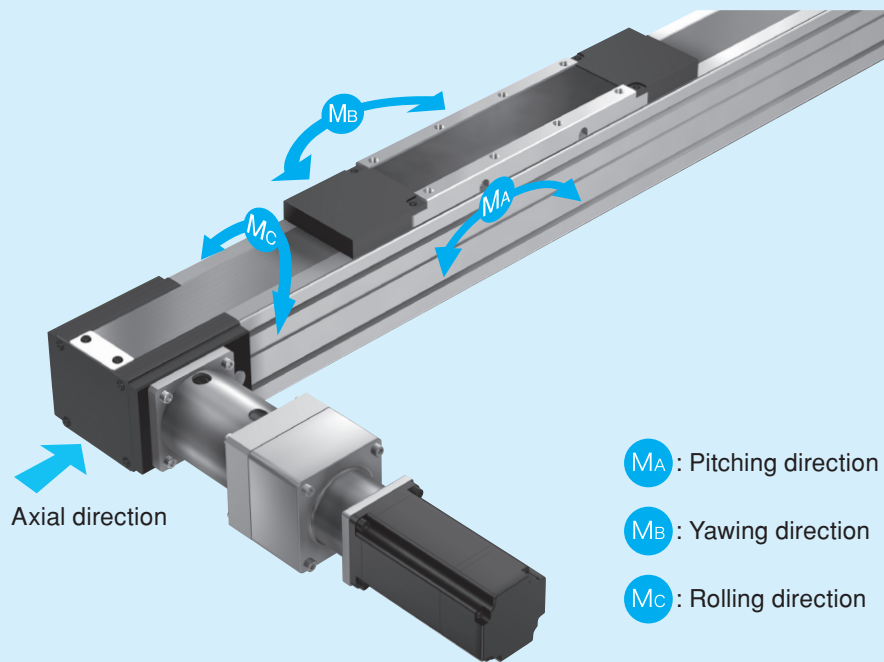

Model TY imposed load / moment direction

Model Number Chart

TY20 - 084 - B1 - C - B

①

②

③

④

⑤

① Model no.	TY20
② Base length	e.g.: if it is 840 mm: 084 if it is 1020 mm: 102
③ Motor bracket	N: No motor bracket For concentric type reducer B1: Pilot diameter \varnothing 50H7, \varnothing 5.5, PCD60 B2: Pilot diameter \varnothing 70H7, \varnothing 6.6, PCD90 U1: Pilot diameter \varnothing 38.1H7, M4, PCD66.66 (NEMA23) V1: Pilot diameter \varnothing 73.03H7, M5, PCD98.43 (NEMA34)
④ Cover	N: No cover C: With a stainless steel cover
⑤ Sensor	N: None B: Photo Sensor EE-SX674 (3 pcs.) H: Proximity Sensor GX-F12A (3 pcs.) J: Proximity Sensor GX-F12A (1pc), GX-F12B (2pcs) P: Proximity Sensor GX-F12A-P (3pcs) M: Proximity Sensor GX-F12A-P (1pc), GX-F12B-P (2pcs)

Model TY20 (No cover)

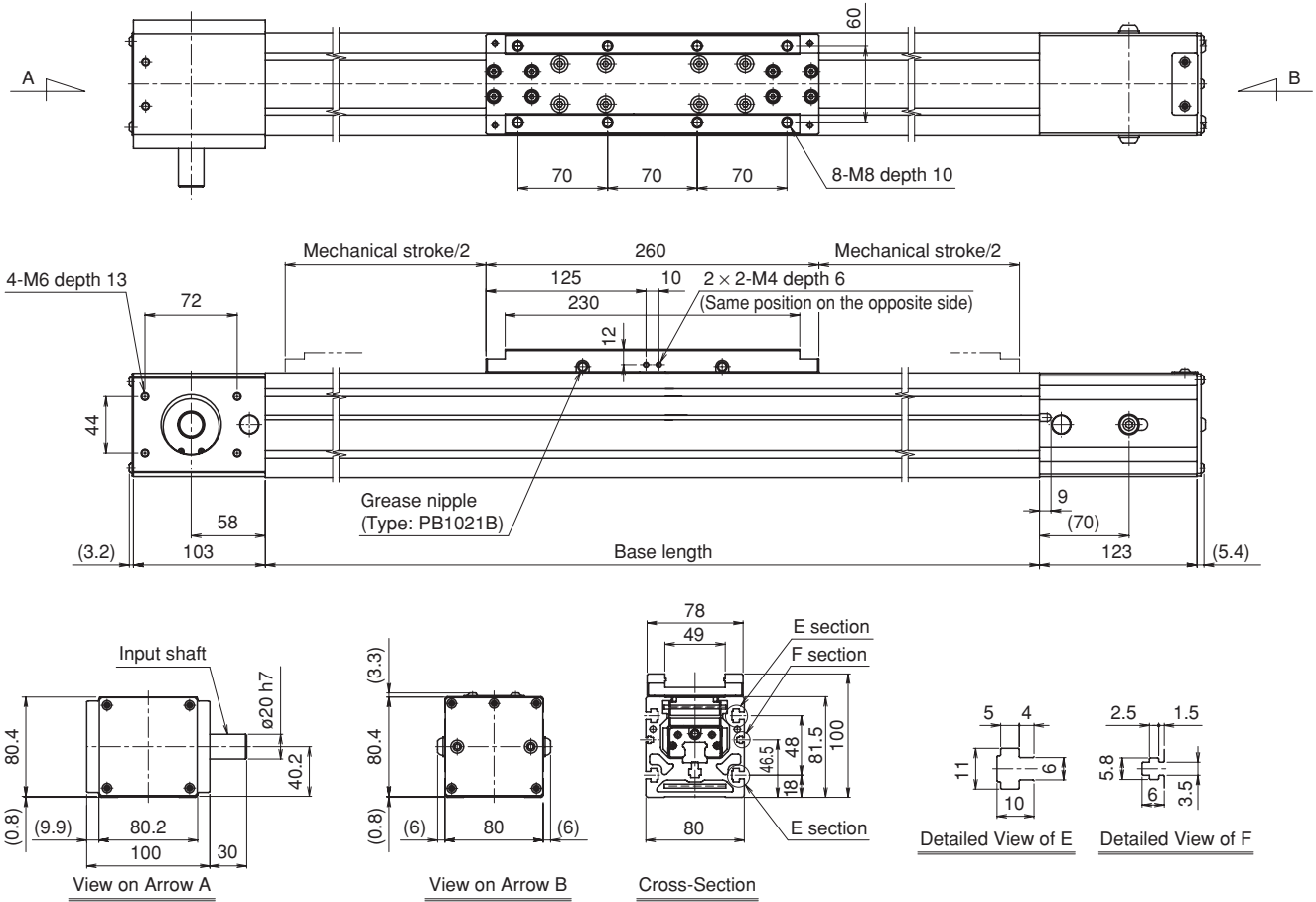

Base length [mm]	840	1020	1320	1620	1920	2220	2520	2820	3120
Mechanical stroke [mm]	549	729	1029	1329	1629	1929	2229	2529	2829
Main unit weight [kg]	13.4	15.1	17.9	20.7	23.5	26.3	29.1	31.9	34.7

Base length [mm]	3420	3720	4020	4320	4620	5040
Mechanical stroke [mm]	3129	3429	3729	4029	4329	4749
Main unit weight [kg]	37.5	40.3	43.1	45.9	48.7	52.6

Note 1) Above figure shows the slider in mid-stroke.

Note 2) Please contact THK for strokes other than those listed above.

Note 3) Please install the unit using the T-slot (E section) on the side (see page 12).

Model TY20 (With stainless steel cover)

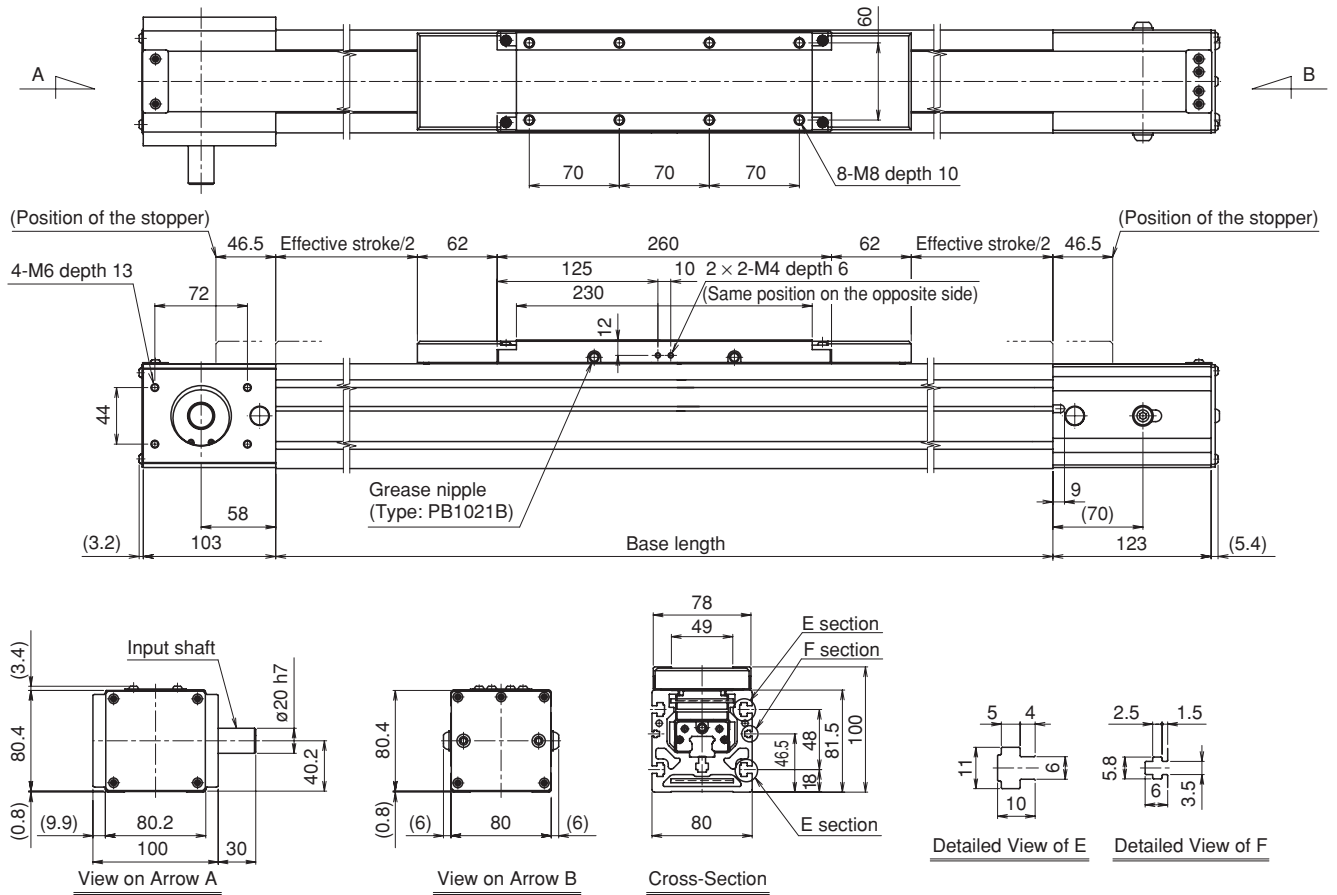

Base length [mm]	840	1020	1320	1620	1920	2220	2520	2820	3120
Mechanical stroke [mm]	549	729	1029	1329	1629	1929	2229	2529	2829
Effective stroke [mm]	456	636	936	1236	1536	1836	2136	2436	2736
Main unit weight [kg]	13.8	15.5	18.3	21.2	24.0	26.8	29.6	32.4	35.2

Base length [mm]	3420
Mechanical stroke [mm]	3129
Effective stroke [mm]	3036
Main unit weight [kg]	38.1

Note 1) Above figure shows the slider in mid-stroke.

Note 2) Please use the actuator within effective strokes. Contact THK for strokes other than those listed above.

Note 3) Please install the unit using the T-slot (E section) on the side (see page 12).

Note 4) The maximum manufacturable base length is 3540 mm for stainless steel cover specifications. Please contact THK for details.

Motor bracket

Motor brackets for various reducers are available.

Table of Supported Motor Bracket for Concentric Type Reducer

Reducer				Symbol
Manufacturer	Model no.	Reduction ratio	Rated output [W]	
Shimpo Drives	VRAFB03	1/3	100	B1
			200	
			400	
	VRAFB05	1/5	100	
			200	
			400	
	VRAFB09	1/9	100	B2
	VRAFB09	1/9	200	
	VRAFC03	1/3	750	
	VRAFC05	1/5		
VRAFC09	1/9	400		

Note 1) The load inertial moment is bigger because this product uses the belt drive method. Using a reducer is recommended.

Note 2) Please see Shimpo Drives, Inc.'s catalog for detailed reducer specifications.

Note 3) If a reducer is installed by THK, please provide the motor manufacturer and model number of the motor.

Motor bracket dimensions

Motor bracket for concentric type reducer (B1, B2)

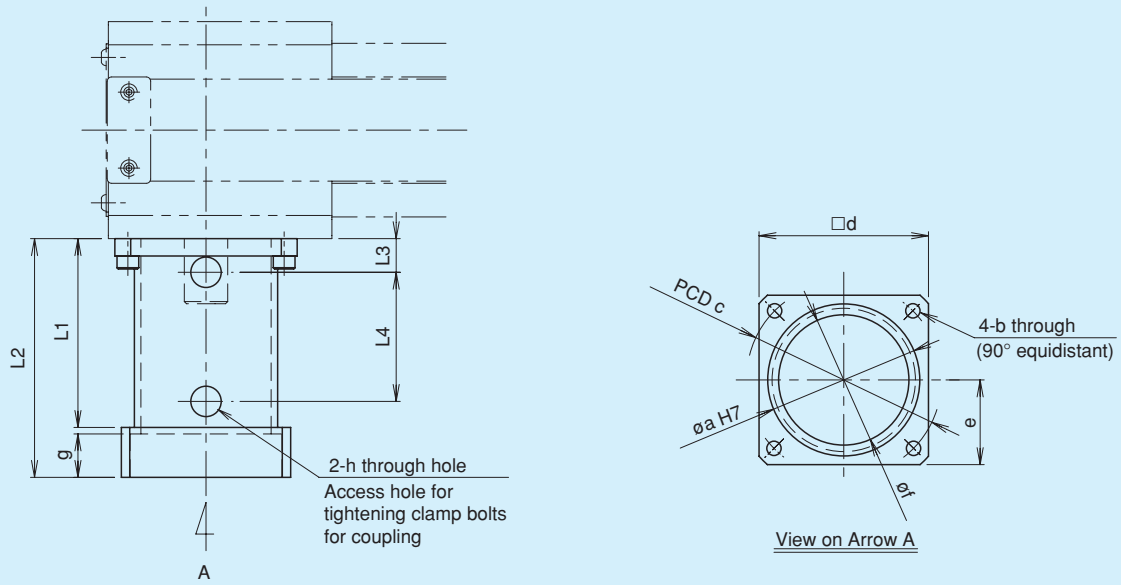

Dimensions of Motor Bracket for Concentric Type Reducer

Unit: mm

Motor bracket code	Motor bracket dimensions											
	a	b	c	d	e	f	g	h	L1	L2	L3	L4
B1	50	5.5	60	56	28	45	14	12	73	87	20	40
B2	70	6.6	90	78	39	60	20	14	90	110	15.5	59.5

Motor bracket for concentric type reducer (U1, V1)

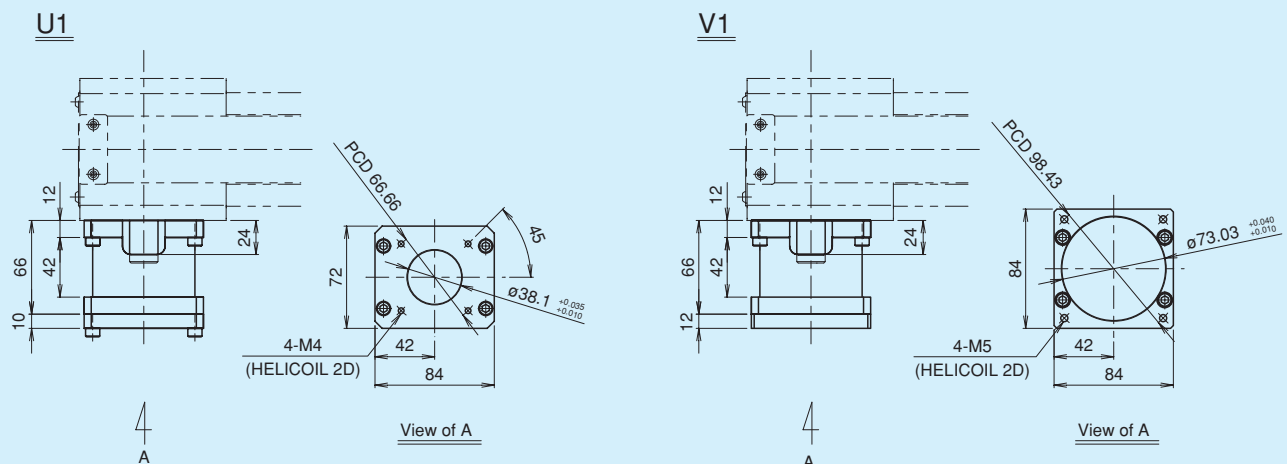

Concentric type reducer

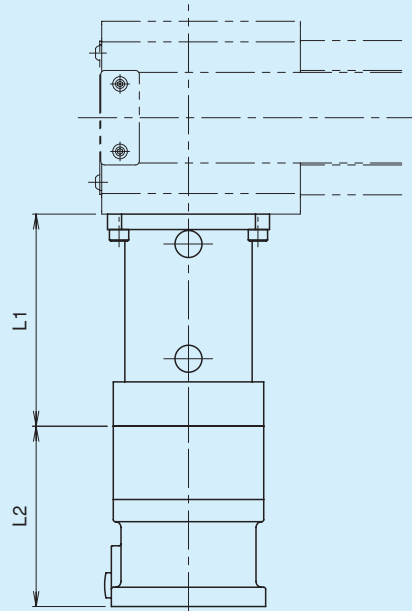

Dimensions When Mounting the Reducer

Reducer				External dimensions of reducer	
Manufacturer	Model no.	Reduction ratio	Rated output [W]	L1	L2*
Shimpo Drives (B Frame)	VRAFB03	1/3	100	87	78
			200		
			400		
	VRAFB05	1/5	100		
			200		
			400		
	VRAFB09	1/9	100		
			200		
	Shimpo Drives (C Frame)	VRAFC03	1/3		
VRAFC05		1/5			
VRAFC09		1/9	400		

* Depends on servo motor, dimension is subject to change.
 THK can provide reducer with unit.
 Please contact THK with combined motor type.

Sensor

Model TY can equip various sensors to the T-groove at the side of the base.

When selecting a sensor, please specify using the corresponding code from the table below.

Tables of Various Sensors

Type	Output operation	Output	Sensor model number	No. of units	Manufacturer	Symbol
Photo Sensor	N.O. / N.C. (selectable)	NPN	EE-SX674	3	OMRON	B
Proximity Sensor	N.O.	NPN	GX-F12A	3	Panasonic Electric Works SUNX	H
	N.O.	NPN	GX-F12A	1		J
	N.C.	NPN	GX-F12B	2		L
	N.O.	PNP	GX-F12A-P	3		M
	N.O.	PNP	GX-F12A-P	1		
	N.C.	PNP	GX-F12B-P	2		

Note 1) GX-F12A-P is not NPN, it is PNP.

Note 2) N.O. contact point is a normally-open type; N.C. contact point is a normally-closed type.

Note 3) Sensors are mounted on the product before being shipped. Please note that a photosensor connector is not included.

Sensor mounting dimensions

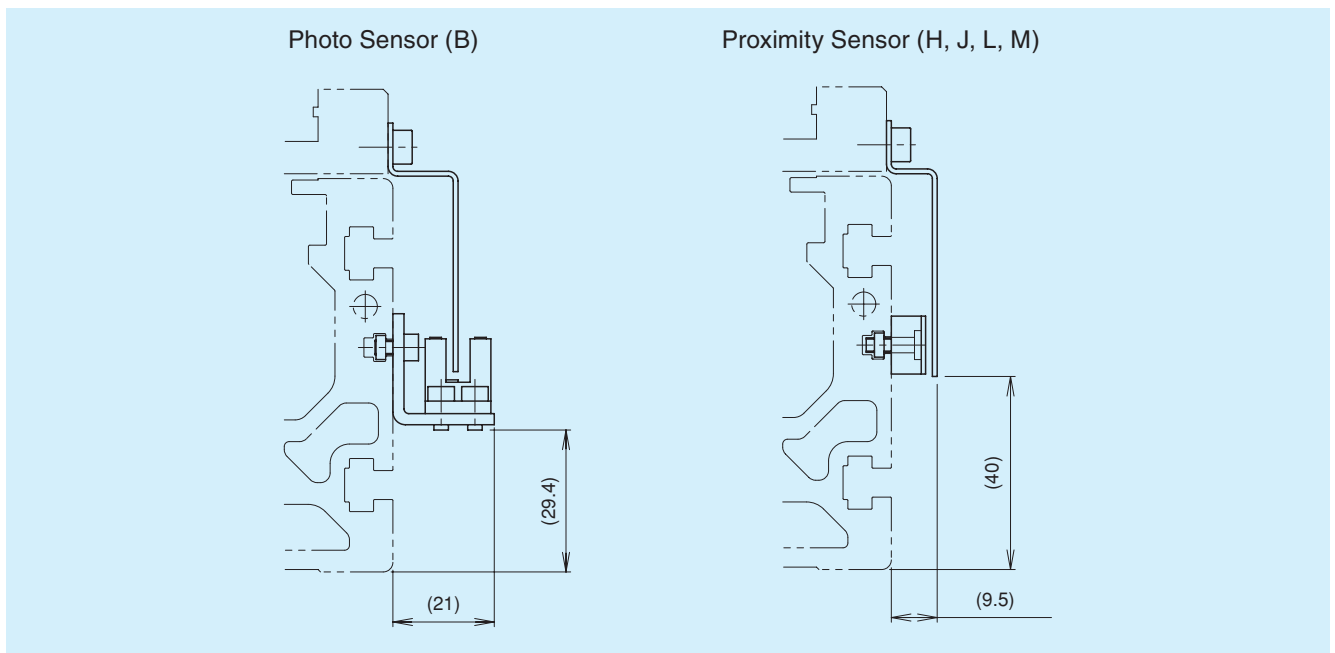

* The direction of the sensor is changeable. The sensor can be removed by sliding the sensor mounting nut from the opposite side of the motor.

Coupling

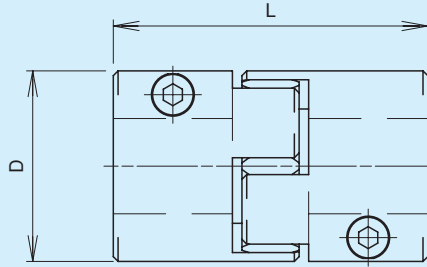

Coupling Model no.	Manufacturer	L [mm]	D [mm]	TY20 Bracket	Applicable Reducers
ALS-040-R-XXB-20B	Miki Pulley	66	40	B1	VRAF-B
ALS-055-R-XXB-20B		78	55	B2	VRAF-C
SC050R-XXB-20B (Max 25 mm)	Zero-Max	60	56	U1, V1	Nema23, Nema34

* Please see the catalog of the coupling manufacturers (Miki Pulley Co., Ltd. and Zero-Max, Inc.) for details.

Base mounting bracket

The mounting brackets for mounting the base are available.

Note) this is not a standard attachment, so please specify the number of pieces required.

Base fixing bracket dimensions
Part Number = TY BASE MOUNTING PLATE

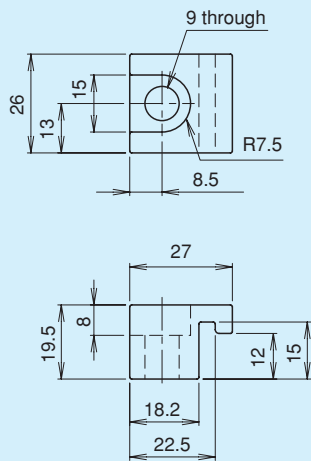

Example of base fixing bracket use (horizontal mount)

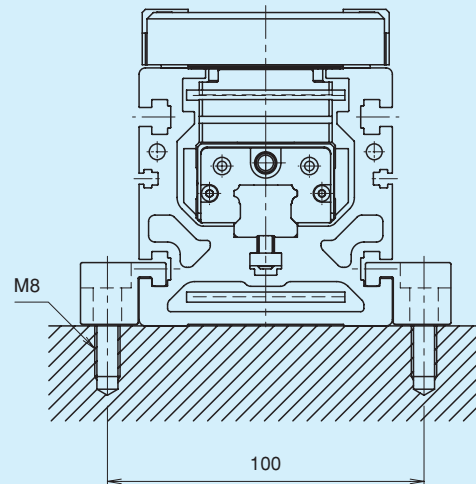

Note 1) Mounting position must be horizontal. If a wall mounting position is used, please contact THK.

Note 2) Mounting intervals of the base fixing brackets should be approximately 250 to 300 mm.

* Mount the base fixing bracket by sliding it from the opposite side of the motor.

Example of mounting the base (horizontal mount)

The diagram below shows a base mounting example without using the base fixing brackets.

Note) Mounting position must be horizontal. If a wall mounting position is used, please contact THK.

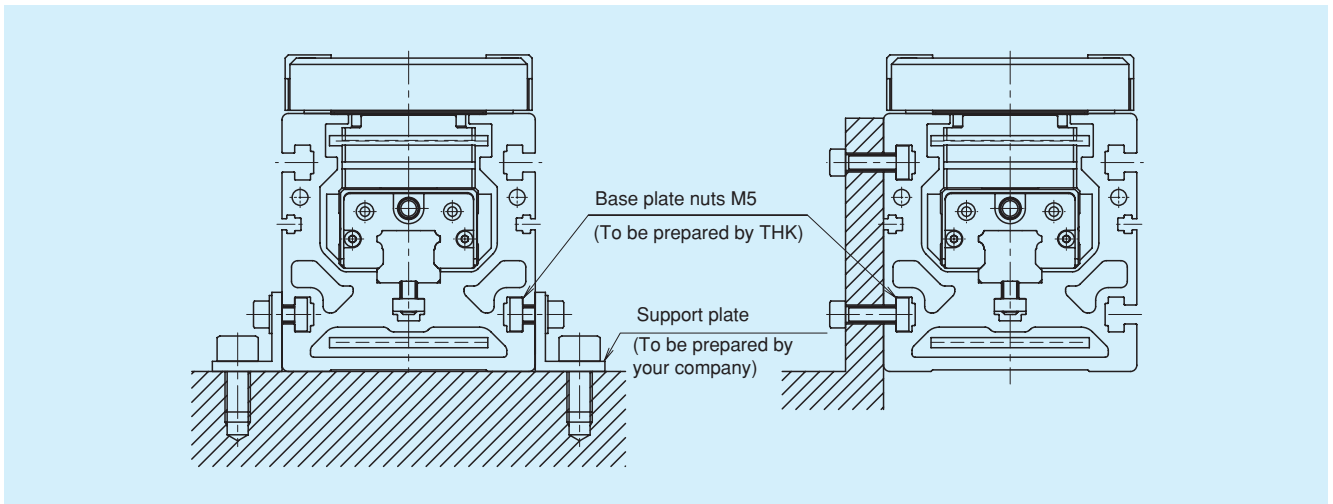

Dimensions of the nuts for mounting the base

The nuts are available for mounting the base that are used for the above mounting example. This is not a standard attachment, so please specify the number of pieces required.

Note) Mounting intervals of the base mounting nut should be approximately 250 to 300 mm.

* Mount the base mounting nut by sliding it from the opposite side of the motor.

Part Number = GL T-NUT-M5

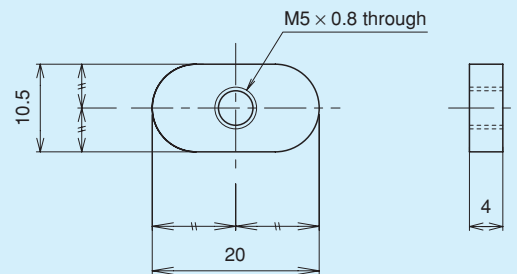

Appendix

Selecting a Model TY

- ① Calculate the service life of the LM Guide from load conditions in order to check that it is sufficiently safe and satisfies the desired service life.
- ↓
- ② Select the motor and check that the output torque of the reducer is the same as permissible input torque of the actuator or less.
- ↓
- ③ Select the options (motor bracket, sensor, cover) as necessary.

Service life / static safety factor

For information about the service life and static safety factor of the TY model LM Guide, see the LM Guide section in the General Catalog. Also, rated life of the LM Guide can be calculated in the THK's technical support site (<https://tech.thk.com/>), or using the technical calculation software that is recorded in the CD catalog. See the data in the table below when calculating rated life.

Note) Please note that the calculation of the service life is a theoretical calculation. Under actual operation, life may vary depending on the operating conditions including operating environment, lubricating condition, mounting accuracy, rigidity, etc.

LM Guide unit

Model no. for LM Guide use	Thrust position		Block span	Movable unit			
	B1 [mm]	B2 [mm]		Mass	Center of gravity position		
			m [kg]	G1 [mm]	G2 [mm]	G3 [mm]	
SHS20V	0	-45	109	1.2	0	54.5	52.2

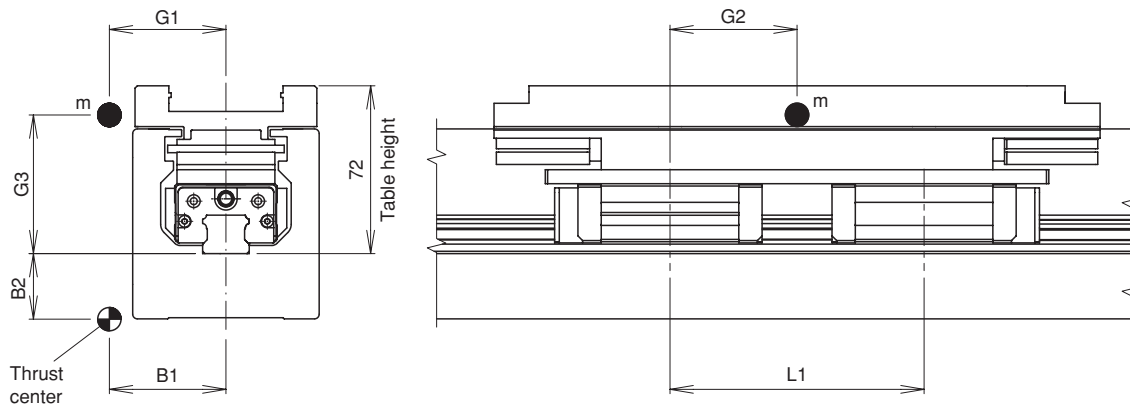

Selecting the motor

When selecting the motor for mounting on Model TY, please select by referring to the data in the table below. Please contact each motor manufacturer for information on motor selection and motor specifications.

Timing belt model no.	Timing pulley		
	Model no.	Pitch diameter [mm]	Inertia (total of two pieces) [kg-cm ²]
050-MA5	41-MA5-050	65.25	5.8

* Belt mass: 0.192 kg/m
 Belt length = base length × 2 + 280 mm

[Reference]

Coupling Model no.	Manufacturer	Inertia [kg-cm ²]
ALS-040-R-XXB-20B	Miki Pulley	0.4
ALS-055-R-XXB-20B		1.63
SC050R-XXB-20B	Zero-Max	1.41

* Please see the catalog of the coupling manufacturers (Miki Pulley Co., Ltd. and Zero-Max, Inc.) for details.

Reducer Model no.	Inertia [kg-cm ²]	Manufacturer
VRAF-B03	0.197	Shimpo Drives
VRAF-B05	0.17	
VRAF-B09	0.162	
VRAF-C03	1.182	
VRAF-C05	0.902	
VRAF-C09	0.821	

* Please see the catalog for the reducer manufacturer (Shimpo Drives, Inc.) for details.

Permissible input torque [N-m]
37.3

Precautions on Use

● Operation

- Unnecessarily disassembling this product may allow foreign objects to enter reduce functionality.
- Do not drop or knock this product. Doing so may cause injury or damage the unit. If the product is dropped or impacted, functionality may be reduced even if there is no surface damage.
- Do not allow foreign matter such as dust and cutting powder to enter. This may damage the ball recirculation part or reduce functionality.
- When the product is in motion or about to be in motion, do not touch any moving parts. Do not go near the actuator when it is in motion.
- If two or more people are involved in the operation, confirm the procedures such as sequences, signs, and abnormalities in advance, and appoint another person for monitoring the operation.
- Anti-rust oil is applied to the input axis for coupling installation. Please wipe the anti-rust oil off completely when installing couplings.
- Mounting position must be horizontal. If a wall mounting position is used, please contact THK.

● Environment

The wrong environment can cause poor production failure. The best places to use the device are as follows:

- An environment with an ambient temperature from 0 to 40°C and humidity of no more than 80% RH that will not expose the product to freezing or condensation.
 - * Contact THK if you are considering using the product in an environment with an operating temperature outside of the specified range.
- A place free from corrosive gas or flammable gas.
- A place free from dust, salt or metal powder.
- A place where water, oil and chemicals will not get on the product.
- Places where vibration or impact are not transmitted to the unit.
- Contact THK if the product will be used in a special environment, such as one with constant vibration, a clean room, a vacuum, or a low-/high-temperature environment.

● Lubrication

- Please use this product after sealing lubricant.
- In order to effectively use this product, lubrication is required. Insufficient lubrication may increase abrasion on the rolling part and shorten service life. THK AFB-LF grease, the standard grease for this product, is enclosed.
- Do not use a mix of lubricants with different physical properties.
- Please contact THK if using special lubricants.
- Please contact THK if using this product with oil lubrication.
- The greasing interval is usually 100 km; however, this may vary depending on the operating conditions, so THK recommends determining a greasing interval during the initial inspection.
- Regular lubricants may not be used when this product is operated in a special environment such as one with constant vibration, a clean room, a vacuum, or low-/ high-temperature environment. In such cases, please contact THK.

● Storage

- When storing the product, enclose it in a package designated by THK and store it in a horizontal orientation while avoiding locations subject to high temperature, low temperature and high humidity.

- “LM GUIDE,” and “” are registered trademarks of THK CO., LTD.
- The actual products may differ from the pictures and photographs in this catalog.
- Outward appearances and specifications is subject to change without notification for purposes of improvement, please inquire before using them.
- Although great care has been taken in the production of this catalog, THK will not take any responsibility for damage resulting from typographical errors or omissions.
- In exporting our products and technology, or selling them for the purpose of export, THK has a basic policy of observing laws relating to foreign exchange, trade and other laws. For export of THK products as single items, contact THK in advance.

All rights reserved

THK CO., LTD.

HEAD OFFICE 3-11-6, NISHI-GOTANDA, SHINAGAWA-KU, TOKYO 141-8503 JAPAN
INTERNATIONAL SALES DEPARTMENT PHONE:+81-3-5434-0351 FAX:+81-3-5434-0353
Global site : <http://www.thk.com/>

NORTH AMERICA

THK America, Inc.
● HEADQUARTERS
Phone:+1-847-310-1111 Fax:+1-847-310-1271
● CHICAGO OFFICE
Phone:+1-847-310-1111 Fax:+1-847-310-1182
● NORTH EAST OFFICE
Phone:+1-631-244-1565 Fax:+1-631-244-1565
● ATLANTA OFFICE
Phone:+1-770-840-7990 Fax:+1-770-840-7897
● LOS ANGELES OFFICE
Phone:+1-949-955-3145 Fax:+1-949-955-3149
● SAN FRANCISCO OFFICE
Phone:+1-925-455-8948 Fax:+1-925-455-8965
● DETROIT OFFICE
Phone:+1-248-858-9330 Fax:+1-248-858-9455
● TORONTO OFFICE
Phone:+1-905-820-7800 Fax:+1-905-820-7811

SOUTH AMERICA

THK BRAZIL INDUSTRIA E COMERCIO LTDA.
Phone:+55-11-3767-0100 Fax:+55-11-3767-0101

EUROPE

THK GmbH
● EUROPEAN HEADQUARTERS
Phone:+49-2102-7425-555 Fax:+49-2102-7425-556
● DÜSSELDORF OFFICE
Phone:+49-2102-7425-0 Fax:+49-2102-7425-299
● STUTTGART OFFICE
Phone:+49-7141-4988-500 Fax:+49-7141-4988-888
● U.K. OFFICE
Phone:+44-1384-47-1550 Fax:+44-1384-47-1551

● ITALY OFFICE

Phone:+39-02-9901-1801 Fax:+39-02-9901-1881

● SWEDEN OFFICE

Phone:+46-8-445-7630 Fax:+46-8-445-7639

● AUSTRIA OFFICE

Phone:+43-7229-51400 Fax:+43-7229-51400-79

● SPAIN OFFICE

Phone:+34-93-652-5740 Fax:+34-93-652-5746

● TURKEY OFFICE

Phone:+90-216-362-4050 Fax:+90-216-569-7150

● PRAGUE OFFICE

Phone:+420-2-41025-100 Fax:+420-2-41025-199

● MOSCOW OFFICE

Phone:+7-495-649-80-47 Fax:+7-495-649-80-44

THK Europe B.V.

● EINDHOVEN OFFICE
Phone:+31-040-290-9500 Fax:+31-040-290-9599

THK France S.A.S.

Phone:+33-4-3749-1400 Fax:+33-4-3749-1401

CHINA

THK (CHINA) CO.,LTD.

● HEADQUARTERS
Phone:+86-411-8733-7111 Fax:+86-411-8733-7000

● SHANGHAI OFFICE

Phone:+86-21-6219-3000 Fax:+86-21-6219-9890

● BEIJING OFFICE

Phone:+86-10-8441-7277 Fax:+86-10-6590-3557

● CHENGDU OFFICE

Phone:+86-28-8526-8025 Fax:+86-28-8525-6357

● GUANGZHOU OFFICE

Phone:+86-20-8523-8418 Fax:+86-20-3801-0456

● SHENZHEN OFFICE

Phone:+86-755-2642-9587 Fax:+86-755-2642-9604

● XIAN OFFICE

Phone:+86-29-8834-1712 Fax:+86-29-8834-1710

THK (SHANGHAI) CO.,LTD.

Phone:+86-21-6275-5280 Fax:+86-21-6219-9890

TAIWAN

THK TAIWAN CO.,LTD.

● TAIPEI HEAD OFFICE

Phone:+886-2-2888-3818 Fax:+886-2-2888-3819

● TAICHUNG OFFICE

Phone:+886-4-2359-1505 Fax:+886-4-2359-1506

● TAINAN OFFICE

Phone:+886-6-289-7668 Fax:+886-6-289-7669

KOREA

SEOUL REPRESENTATIVE OFFICE

Phone:+82-2-3468-4351 Fax:+82-2-3468-4353

SINGAPORE

THK LM SYSTEM Pte. Ltd.

Phone:+65-6884-5500 Fax:+65-6884-5550

THAILAND

THK LM System Pte.Ltd.Representative Office in Thailand

Phone:+660-2751-3001 Fax:+660-2751-3003

INDIA

THK India Pvt. Ltd.

Phone:+91-80-2340-9934 Fax:+91-80-2340-9937